

NAVAIR 17-20AQ-289

TECHNICAL MANUAL

INSTRUMENT CALIBRATION PROCEDURE

AQ-289

COMMUNICATIONS SERVICE MONITORS

IFR INC.

FM/AM-1500, FM/AM-1500OPT01, 02,
AND FM/AM-1500OPT02



THIS PUBLICATION SUPERSEDES NAVAIR 17-20AQ-289
DATED 1 NOVEMBER 1990

DISTRIBUTION STATEMENT C. DISTRIBUTION AUTHORIZED TO U.S. GOVERNMENT AGENCIES AND THEIR CONTRACTORS TO PROTECT PUBLICATIONS REQUIRED FOR OFFICIAL USE OR FOR ADMINISTRATIVE OR OPERATIONAL PURPOSES ONLY. OTHER REQUESTS FOR THIS DOCUMENT SHALL BE REFERRED TO NAVY MEASUREMENT SCIENCE DIRECTORATE, NAVAL WARFARE ASSESSMENT DIVISION, P.O. BOX 5000 CORONA, CA 91718-5000

AQ-289

DESTRUCTION NOTICE- FOR UNCLASSIFIED, LIMITED DOCUMENTS, DESTROY BY ANY METHOD THAT WILL PREVENT DISCLOSURE OF CONTENTS OR "RECONSTRUCTION OF THE DOCUMENT."

PUBLISHED BY DIRECTION OF COMMANDER NAVAL AIR SYSTEMS COMMAND

1 APRIL 1994

LIST OF EFFECTIVE PAGES

Insert latest changed pages; dispose of superseded pages in accordance with applicable regulations.

NOTE: On a changed page, the portion of the text affected by the latest change is indicated by a vertical line, or other change symbol, in the outer margin of the page.

| Page No. | Change No. * | Change Date | Page No. | Change No. * | Change Date |
|----------|--------------|-------------|----------|--------------|-------------|
| Title | 0 | | | | |
| A | 0 | | | | |
| i | 0 | | | | |
| 1 to 44 | 0 | | | | |
| A-1 | 0 | | | | |

* Zero in this column indicates an original page.

TABLE OF CONTENTS

| Section | | Page |
|---------|---|------|
| 1 | Introduction and Description | 1 |
| 2 | Equipment Requirements | 5 |
| 3 | Preliminary Operations | 8 |
| 4 | Calibration Process | 9 |
| 4.1 | Self-Tests, Functional, and Power Supply Checks | 9 |
| 4.2 | RF Signal Generator Tests | 11 |
| 4.3 | Duplex Generator Tests | 13 |
| 4.4 | Receiver/Monitor Tests | 15 |
| 4.5 | Spectrum Analyzer Tests | 20 |
| 4.6 | Oscilloscope Tests | 22 |
| 4.7 | Dual Tone Generator Tests | 24 |
| 4.8 | Frequency Error Meter Tests | 26 |
| 4.9 | Internal SINAD Meter Test | 27 |
| 4.10 | Power Monitor Tests | 28 |
| 4.11 | IEEE Bus Test (TI's W/Option 01 Only) | 31 |
| | Navy Calibration Checklist | 33 |
| | Appendix A | A-1 |

ILLUSTRATIONS

| Figure | | Page |
|--------|--|------|
| 1 | EXT ACC Pin Layout Configuration | 11 |
| 2 | Dual Tone Generator Test Configuration | 24 |
| 3 | SINAD Preliminary Test Configuration | 27 |
| 4 | Power Monitor Test Configuration Using Power Standard Assembly | 29 |
| 5 | Power Monitor Test Configuration Using Directional Coupler | 30 |

TABLES

| Table | | Page |
|-------|-------------------------------|------|
| 1 | Calibration Description | 1 |

SECTION 1

INTRODUCTION AND DESCRIPTION

1.1 This procedure describes the calibration of the IFR Inc. FM/AM-1500, FM/AM-1500OPT01, 02 and FM/AM-1500OPT02 Communications Service Monitors. The instrument being calibrated is referred to herein as the TI (Test Instrument).

1.2 All comments concerning this procedure should be directed to Navy Measurement Science Directorate, Naval Warfare Assessment Division, P.O. Box 5000, Corona, CA 91718-5000.

1.3 This procedure includes tests of essential performance parameters only. Any malfunction noticed during calibration, whether specifically tested for or not, should be corrected.

1.4 This procedure can be performed utilizing equipment found in workstations 1B, 3B, 5B, and 6A.

Table 1. Calibration Description

| TI Characteristics | Performance Specifications | Test Method |
|------------------------------|--|--|
| Type N connector | Meets MIL-C-39012 critical dimension specification | Measured with a standardized coaxial gage. |
| Self Tests/Functional Checks | Proper TI front panel indication of passage of self tests and functional checks of internal microprocessor | Checked using TI internal software programming. |
| Power supply | Test voltages: +12 \pm 0.5 V dc; +5.075 \pm 0.225 V dc; -12 \pm 0.5 V dc | Checked at TI EXT ACC connector to ensure proper operation of certain voltages of the TI internal DC power supply. |
| <u>RF signal generator</u> | | |
| Frequency | Frequency range: 100 Hz to 999.9999 MHz Resolution: 100 Hz Tolerance: \pm 0.5 ppm; \pm 0.05 ppm, option 02 Aging: \pm 2 ppm per year; \pm 0.25 ppm per year, option 02 | Tested using an electronic counter. |
| Output level | Range: 0 to -128 dBm Tolerance: \pm 2 dB, -10 to -80 dBm; \pm 2.5 dB, -80 to -128 dBm | Tested using a signal generator calibrator. |
| FM modulation | Deviation range: 0 to \pm 25 kHz Tolerance: 6 V p-p \pm 2 V p-p produces \pm 15 kHz deviation Rate: 2 Hz to 30 kHz Flatness: \pm 2 dB Distortion: <2% at \pm 25 kHz deviation and from 200 Hz to 20 kHz rate | Not tested. |

| TI Characteristics | Performance Specifications | Test Method |
|---------------------------------------|--|--|
| AM modulation | AM depth range: 0 to 90% Tolerance: 3 V p-p \pm 1 V p-p produces 90% modulation Rate: 10 Hz to 5 kHz, 0 to 90% AM depth; 6 kHz to 30 kHz, 0 to 30% AM depth | Not tested. |
| Residual FM | <50 Hz rms in a 50 Hz to 300 Hz bandwidth | Tested using a signal generator calibrator. |
| Spurious signals | Harmonics: >25 dBc Non-harmonics: >40 dBc | Tested using a spectrum analyzer. |
| <u>Duplex Generator</u> | | |
| Frequency | Frequency range: \pm 49.99 MHz from receiver frequency Tolerance: \pm 0.5 ppm; \pm 0.05 ppm, option 02 | Tested using an electronic counter. |
| Output level | DUPLEX output range: 0 to -128 dBm Tolerance: \pm 2 dB, -10 to -80 dBm; \pm 2.5 dB, -80 to -128 dBm TRANS output range: 40 dB below attenuator setting (-40 to -168 dBm) Tolerance: \pm 3 dB, -40 to -120 dBm; \pm 3.5 dB, -120 to -168 dBm | Tested using a signal generator calibrator. |
| <u>Receiver/Monitor</u> | | |
| Frequency | Frequency range: 300 kHz to 999.9999 MHz Resolution: 100 Hz | Tested by inference during receiver tests. |
| Receiver sensitivity | Sensitivity: \leq -99 dBm in a 15 kHz pre-detection bandwidth; \leq -90 dBm in a 200 kHz pre-detection bandwidth | Tested using a signal generator. |
| Antenna attenuator | Range: 0, 20, and 40 dB positions Tolerance: \pm 2 dB | Tested during TI Spectrum Analyzer tests. |
| Adjacent channel rejection | >25 dB at \pm 25 kHz >40 dB at \pm 50 kHz | Tested using a signal generator. |
| FM demodulation noise + distortion | <2% at \pm 25 kHz deviation for rates from 200 Hz to 20 kHz with receiver input level of -50 dBm | Tested using a signal generator calibrator and signal generator. |

| TI Characteristics | Performance Specifications | Test Method |
|-------------------------------------|---|---|
| Analog deviation meter | Range: 2 kHz, 6 kHz, 20 kHz, and 60 kHz ranges* Tolerance: $\pm 5\%$ of fullscale for rates from 30 Hz to 10 kHz at a signal level of -50 dBm | Tested using a signal generator calibrator and signal generator. |
| Analog AM modulation meter | AM depth range: 20%, 60%, and 200% ranges Tolerance: $\pm 7\%$ of reading $\pm 5\%$ of fullscale | Tested using a signal generator calibrator and signal generator. |
| Digital deviation display (CRT) | Meter range: 0.00 to 60.0 kHz Tolerance: $\pm 3\%$ for 6 kHz rate at ± 2 kHz with 8 kHz post detection bandwidth; $\pm 3\%$ for 10 kHz rate at ± 8 kHz with 20 kHz post detection bandwidth Scope range: .5 kHz/DIV to 20 kHz/DIV Tolerance: $\pm 10\%$ | Tested using a signal generator calibrator and signal generator. |
| Digital AM modulation display (CRT) | AM depth range: 20%, 60%, 200%, and 600% ranges Tolerance: $\pm 5\%$ of reading ± 20 counts for rates from 300 Hz to 10 kHz at a signal level of -50 dBm | Tested using a signal generator calibrator and signal generator. |
| Spectrum analyzer | Range: -30 to -90 dBm Tolerance: ± 2 dB linearity Dynamic range: 70 dB, up to an additional 40 dB selectable using antenna attenuator Span range: 1 kHz to 10 MHz per division, with a full span (1 MHz to 1000 MHz) available Tolerance: ± 0.3 div for a 4 division left or right shift from the center vertical graticule Bandwidth: 300 Hz to 600 kHz | Tested using a signal generator calibrator and signal generator. |
| Tracking/Sweep generator | Frequency range: 1 to 1000 MHz Output level: same as RF signal generator Flatness: ≤ 4 dB per division and ≤ 6 dB across entire bandwidth with span at FULL | Sweep function not tested. Output level accuracy tested during the TI RF Signal Generator tests. Tracking flatness tested using the TI RF Signal Generator and the CRT. |

* Depending on the TI version, some may have a 120 kHz range vice a 60 kHz range.

| TI Characteristics | Performance Specifications | Test Method |
|-------------------------------------|--|--|
| Oscilloscope | Vertical bandwidth: DC to 1 MHz Vertical input ranges: 10 mV, 100 mV, 1 V, and 10 V per division Tolerance: $\pm 10\%$ Horizontal sweep ranges: 10 ms, 1 ms, 100 $\mu\sigma$, and 10 $\mu\sigma$ per division Tolerance: $\pm 20\%$ | Tested using an ac calibrator and a function generator. |
| <u>Dual tone generator</u> | | |
| Frequency | Frequency range: 2 Hz to 30 kHz Tolerance: $\pm 0.01\%$ Resolution: 0.1 Hz, 2 to 9999.9 Hz; 1 Hz, 10 to 30 kHz | Tested using an electronic counter. |
| Output level | Range: 0 to 2.5 V rms minimum into 150 Ω | Tested using a DMM. |
| Distortion | <2%, 10 Hz to 100 Hz <0.7%, 100 Hz to 30 kHz | Tested using a distortion analyzer. |
| <u>Frequency error meter</u> | | |
| RF signals | Ranges: ± 30 Hz to ± 10 kHz in 3, 1 steps Tolerance: ± 1 minor div Sensitivity: 1.5 μV above 1 MHz RF signal | Tested using a signal generator. |
| Demodulated audio signals | Ranges: ± 3 Hz, ± 30 Hz, and ± 300 Hz referenced to Tone Generator #1 Resolution: ± 0.1 Hz on ± 3 Hz range Modulation rate frequency range: 20 Hz to 10 kHz | Not tested. |
| Demodulated audio frequency counter | Range: 10 Hz to 20 kHz Tolerance: ± 2 counts Resolution: 1 Hz | Tested during TI Dual Tone Generator tests. |
| Internal sinad meter | Input range: 0.5 to 10 V rms Frequency: 1 kHz Sinad range: 0 to 20 dB Tolerance: ± 1.0 dB at 12 dB reading | Tested using a DMM and the TI Dual Tone Generator signals. |

| TI Characteristics | Performance Specifications | Test Method |
|--------------------------------------|---|---|
| Power monitor | Frequency range: 1 MHz to 1000.00 MHz Power ranges: 0 to 15 and 0 to 150 Watts Tolerance: $\pm(7\%$ of reading + 3% of fullscale), 1 to 600 MHz; $\pm(17\%$ of reading + 3% of fullscale, 600 to 821 and 896 to 1000 MHz; $\pm(7\%$ of reading + 3% of fullscale), 821 to 896 MHz | Tested by comparing the power measured by the TI and a power meter (using a power standard assembly at 30 and 400 MHz, and then using a directional coupler and thermistor mount at 800 and 850 MHz). |
| IEEE-488 (GPIB) data bus (Option 01) | Conforms to IEEE std 488-1978 for Talker and Listener | Tested with an Instrument Controller using an IEEE Bus tester program. |

SECTION 2

EQUIPMENT REQUIREMENTS

NOTE

Minimum use specifications are the principal parameters required for performance of the calibration, and are included to assist in the selection of alternate equipment, which may be used at the discretion of the using laboratory. Satisfactory performance of alternate items shall be verified prior to use. All applicable equipment must bear evidence of current calibration.

The instruments utilized in this procedure were selected from those known to be available at Navy calibration facilities, and the listing by make or model number carries no implication of preference, recommendation, or approval for use by other agencies. It is recognized that equivalent equipment produced by other manufacturers may be capable of equally satisfactory performance in this procedure.

| Item | Minimum Use Specifications | Calibration Equipment |
|------------------------------|---|--|
| 2.1 Coaxial gage | ± 0.001 inch | Maury Microwave A007A or A007 |
| 2.2 Digital multimeter (DMM) | DC voltage range: -13 to +13 V dc Uncertainty: $\pm 1\%$ AC voltage range: 2 to >3 V rms Uncertainty: $\pm 0.05\%$ | Fluke 8840AAFOPT005, 8506AAN, or 8502AAT |

| Item | Minimum Use Specifications | Calibration Equipment |
|----------------------------------|--|---|
| 2.3 Electronic counter | Frequency range: 20 Hz to 1 GHz Uncertainty: $\pm 1 \times 10^{-8}$ Resolution: 5 digits, frequencies <100 kHz; 9 digits, frequencies ≥ 100 kHz | Hewlett-Packard 5345AOPT012 with 5355A plug-in, or 5334BOPT030, or 5335AOPT010,030,040 |
| 2.4 Calibrator, signal generator | Power range: 0 to -100 dBm 10 to 1000 MHz Uncertainty: ± 0.50 dB Frequency modulation deviation range: 50 Hz to 50 kHz Uncertainty: $\pm 1\%$ Amplitude modulation range: 15% to 80% Uncertainty: $\pm 2.25\%$ depth | Hewlett-Packard 8902AOPTE02 (consists of: 8902AOPT002 and 11722A; or 8902AOPTE04 (consists of: 8902A; 8672AOPT001,008; 11792AOPT001,H04; and 11793AOPTH04) |
| 2.5 Spectrum analyzer | Frequency range: 100 kHz to 1 GHz Sensitivity: ability to discern signals greater than 40 dBc | Hewlett-Packard 8562AOPTE51 or 8562AOPTE50 |
| 2.6 50 ohm load | Frequency range: 20 MHz to 810 MHz Impedance: 50 ohms | Local supply |
| 2.7 Signal generator | Frequency range: 30 MHz to 1 GHz Uncertainty: ± 0.04 ppm Resolution: 1 Hz at 120 MHz; 1 kHz, elsewhere Output level range: +10 to -100 dBm Uncertainty: ± 2 dB FM modulation: 1 kHz to 50 kHz deviation at a modulation rate of 1 to 10 kHz AM modulation: 15% to 80% AM depth at a modulation rate of 1 kHz | Hewlett-Packard 8642BOPT001,710,907, or 8642BOPT001,907; or Fluke 6071AOPT130 |
| 2.8 Distortion analyzer | Capable of measuring distortion down to 0.7% at 1 kHz fundamental | Hewlett-Packard 8903BOPT050,907,910, 334A, or 332A; or Sound Technology 1700BOPT003,005 |
| 2.9 Power divider | Frequency use: 120 MHz Insertional loss: 6 dB nom. each arm | Weinschel 1870A or 1506A; or Hewlett-Packard 11667A |
| 2.10 AC calibrator | Voltage range: 50 mV p-p to 50 V p-p Uncertainty: $\pm 2.5\%$ Frequency: 1 kHz | Fluke 5200A, 5102BOPT003,005, or 5100BOPT003,005 |
| 2.11 Function generator | Frequency range: 100 Hz to 100 kHz Uncertainty: $\pm 1\%$ Voltage: 2 V p-p (0.707 V rms) Uncertainty: $\pm 0.5\%$ | Fluke 6011AOPT01,02, 05 or 6011AOPT01, 03,05 |
| 2.12 Resistor | 150 Ω , 1/4 Watt | Local supply |

| Item | Minimum Use Specifications | Calibration Equipment |
|-----------------------------------|--|--|
| 2.13 Power meter | Power range: 10 μ W fs to 10 mW fs Uncertainty: \pm 1% Compatible with items 2.14 and 2.16 | Hewlett-Packard 432A |
| 2.14 Power standard assembly | Frequency range: 30 to 400 MHz Power range: 3 to 80 Watts Total system uncertainty: accompanied by a Report of Calibration from a Type I or Type II Laboratory Thermistor mount compatible with item 2.13 | Maury 4098F or 4098F2 |
| 2.15 High power amplifier | Frequency range: 30 to 400 MHz Output power: 100 W CW min. Gain: 40 dB min. | Electronic Navigation Industries 5100L |
| 2.16 Thermistor mount | Frequency range: 800 to 850 MHz Power range: 1 μ W to 10 mW Type: coaxial temperature compensated Compatible with item 2.13 Accompanied by a NSL Report of Calibration at 800 and 850 MHz | Hewlett-Packard 478AOPHT75 |
| 2.17 Coaxial directional coupler | Frequency range: 800 to 850 MHz Power range: 3 Watts CW maximum Coupling: 30 dB nom. Accompanied by a NSL Report of Calibration at 800 and 850 MHz | Narda 3001-30-01 or 3001-30 |
| 2.18 Low power amplifier | Frequency range: 800 to 850 MHz Output power: 3 W CW min. | Electronic Navigation Industries 603LN |
| 2.19 Instrument controller | Programmable using diskette NAVAIR 17-20MSYS-036D, version 2 or 3 (or 4), IEEE-488 GPIB test for use with Fluke 1722A/AP | Fluke or 1722A/AP |
| 2.20 Interface bus cable | Meets IEEE Std. 488-1978 and FCC regulation 79-555-14686 | Local supply |
| 2.21 Cables, tees, adapters, etc. | As required | Local supply |

SECTION 3

PRELIMINARY OPERATIONS

3.1 Ensure that all power switches are set to off, and set all auxiliary equipment controls as necessary to avoid damage to the equipment and so that dangerous voltages will not be present on output terminals when the power switches are turned on.

3.2 Using the coaxial gage, verify that the TI type N connector dimensions are within the tolerance limits specified in Appendix A, as applicable.

3.3 Adjust the TI MODULATION meter mechanical zero screwdriver adjustment for an indication as close as possible to "0" on the MODULATION meter. Gently tap on the TI MODULATION meter faceplate to ensure that the needle is not sticking and that it settles to "0".

3.4 Adjust the TI FREQ ERROR meter mechanical zero screwdriver adjustment for an indication as close as possible to "0" on the FREQ ERROR meter. Gently tap on the TI FREQ ERROR meter faceplate to ensure that the needle is not sticking and that it settles to "0".

3.5 Set the TI controls as follows:

| | |
|-----------------------------------|------------------|
| DISPLAY switch to | OFF |
| INTENSITY control to | midrange |
| FOCUS control to | midrange |
| VERT POS control to | midrange |
| HORIZ POS control to | midrange |
| VERT VERNIER control to | fully cw (CAL) |
| HORIZ VERNIER control to | fully cw (CAL) |
| VOLUME control to | fully ccw |
| SQUELCH control to | fully ccw |
| Tone 1 FM/OFF/AM toggle switch to | OFF |
| Tone 2 FM/OFF/AM toggle switch to | OFF |
| TONE 1 control to | fully ccw |
| TONE 2 control to | fully ccw |
| GEN control to | fully ccw (LOCK) |
| GEN/REC toggle switch to | GEN |
| DUPLEX/SIMPLEX toggle switch to | SIMPLEX |
| ATTENUATOR toggle switch to | 40 dB |
| Attenuator dial (or RF LEVEL) to | -10 dBm |
| DEV/PWR toggle switch to | PEAK (down) |
| DEV-PWR switch to | 2 kHz |
| HORIZ switch to | 1 ms/DIV |
| INT TONE/RCVR toggle switch to | RCVR |

| | |
|-------------------------|------------|
| dB/DIV toggle switch to | 10 |
| DC/AC toggle switch to | AC |
| ANALY DISPR switch to | 20 kHz/DIV |
| DEV-VERT switch to | .5 kHz/DIV |
| FREQ ERROR switch to | 1 kHz |
| MODULATION switch to | FM 4 |

3.6 Connect the TI and the auxiliary equipment to the appropriate power source.

3.7 Turn all power switches to on (set the TI PWR/OFF/BATT switch to PWR) and allow a sufficient warm-up time for the equipment (the TI requires a 15 minute warm-up time).

3.8 If TI is equipped with a battery, press and hold the TI BATT TEST pushbutton and ensure that the TI MODULATION meter indication falls within the BATT region on the upper scale; if not, take appropriate corrective action. Release the TI BATT TEST pushbutton.

SECTION 4

CALIBRATION PROCESS

NOTE

Unless otherwise specified, verify the results of each test and take corrective action whenever the test requirement is not met, before proceeding.

4.1 SELF TESTS, FUNCTIONAL, AND POWER SUPPLY CHECKS

NOTE

Throughout this test, adjust the TI INTENSITY and FOCUS controls as necessary for a proper display on the TI CRT.

4.1.1 Self Test and Functional Checks

4.1.1.1 Set the TI VOLUME control to midrange.

4.1.1.2 Press each key on the TI Keypad and verify that an audible tone is generated each time a key is pressed.

4.1.1.3 Set the TI VOLUME control fully ccw.

4.1.1.4 Set the TI DISPLAY switch to TRACK, and verify that a noise pattern is displayed at the bottom of the CRT.

4.1.1.5 Set the TI DISPLAY switch to SWEEP, and verify that a horizontal trace is displayed on the center horizontal graticule of the CRT.

4.1.1.6 Set the TI DISPLAY switch to FREQS. Press the TI "MENU" and "V" keyboard keys successively, and verify that the RF MEMORY, CABLE FAULT, RF SCAN, and RF SWEEP menus are displayed on the CRT.

4.1.1.7 Set the TI DISPLAY switch to TONES. Press the TI "MENU" and "V" keyboard keys successively, and verify that the TONE SEQUENCE, DIGITALLY-CODED SQUELCH, TONE SWEEP, and DTMF menus are displayed on the CRT.

4.1.1.8 Set the TI DISPLAY switch to HELP. Press the TI "MENU" and "V" keyboard keys successively, and verify that the LCD MANUAL DATA, MEMORY STORAGE, MEMORY RECALL, SELF-TESTS, and OPERATOR's MENU menus are displayed on the CRT.

4.1.1.9 Press the TI "MENU" and "V" or keyboard keys successively until the SELF-TESTS menu is displayed on the CRT.

4.1.1.10 Press the following TI keyboard sequence: EXEC, 1, and ENTER. Verify that the TI LCD display FREQUENCY MHz field starts at 00000 and increments by 1 (indicating successful memory tests), and that the OFFSET MHz field stays at 00000 (indicating no memory test failures). Press the TI "ENTER" key to exit the self-test.

4.1.1.11 Press the following TI keyboard sequence: EXEC, 2, and ENTER. Verify that the TI CRT characters can be changed by depressing the TI "V" and "^" keys, and steps through the entire alphanumeric character set. Press the TI "ENTER" key to exit the self-test.

4.1.1.12 Press the following TI keyboard sequence: EXEC, 3, and ENTER. Verify that the TI LCD displays scrolls from right to left. Press the TI "ENTER" key to exit the self-test.

4.1.1.13 Press the following TI keyboard sequence: EXEC, 4, and ENTER. Verify that the TI LCD display flickers, the Freq LOCK indicator flashes, the LED's around the MODULATION switch flash, and that the LCD display does not indicate an error message (OFFSET MHz field count is 00000). Press the TI "ENTER" key to exit the self-test.

4.1.1.14 Press the following TI keyboard sequence: EXEC, 5, and ENTER. Verify that the cursor is displayed and, if applicable, the last stored menu. Press the TI "ENTER" key to exit the self-test.

4.1.1.15 Set the TI METER switch to METER.

4.1.2 Power Supply Checks

4.1.2.1 Set the DMM for autoranging dc voltage measurements.

4.1.2.2 Connect the DMM positive lead to the TI EXT ACC pin 1 connector and the DMM negative lead to the TI EXT ACC pin 9 connector. See Figure 1 for pin layout of the TI EXT ACC connector.

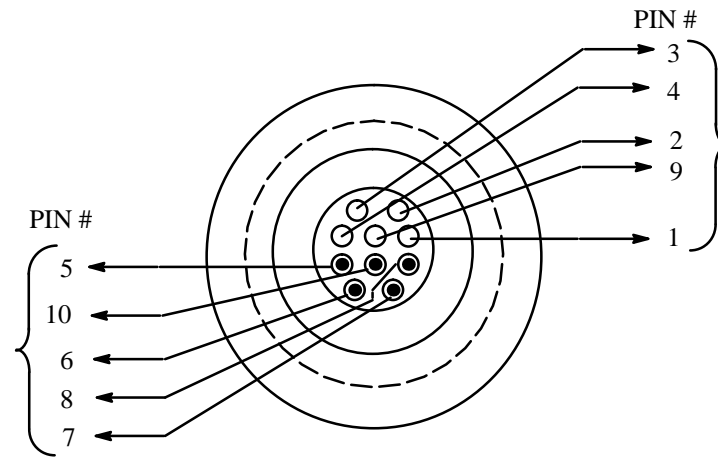

Figure 1. EXT ACC Pin Layout Configuration

4.1.2.3 Verify that the DMM indicates between +11.5 and +12.5 V dc.

4.1.2.4 Move the DMM positive lead to the TI EXT ACC pin 3 connector (see Figure 1), and verify that the DMM indicates between +4.85 and +5.30 V dc.

4.1.2.5 Move the DMM positive lead to the TI EXT ACC pin 2 connector (see Figure 1), and verify that the DMM indicates between -11.5 and -12.5 V dc.

4.1.2.6 Disconnect the DMM from the TI.

4.2 RF SIGNAL GENERATOR TESTS

4.2.1 RF Frequency Accuracy Tests

4.2.1.1 Connect the electronic counter input to the TI 10 MHz REF connector (rear panel).

4.2.1.2 Set the electronic counter for frequency measurements with a 50 ohm input impedance, as applicable.

4.2.1.3 Verify that the electronic counter indication is between 9.999995 and 10.000005 MHz (9.9999995 and 10.0000005 MHz, TI's with option 02).

4.2.1.4 Disconnect the electronic counter from the TI 10 MHz REF connector and reconnect it to the TI TRANS/-40 dB DUPLEX connector.

4.2.1.5 Set the TI for a RF frequency of 500 kHz by pressing the following keypad sequence: RF, 0, ., 5, 0, 0, 0, ENTER. Ensure that the TI LCD FREQUENCY MHz display indicates 0.5000.

4.2.1.6 Verify that the electronic counter indication is between 499.99975 and 500.00025 kHz (499.999975 and 500.000025 kHz, TI's with option 02).

4.2.1.7 Using the method described in step 4.2.1.5, set the TI for the following RF frequencies. At each setting, verify that the electronic counter indicates within the tolerance limits listed.

| TI RF Frequency Setting (MHz) | Electronic Counter Tolerance Limits (MHz) | | | |
|-------------------------------------|---|----|--------------|--------------------------|
| | TIs W/Out OPT02 | | TIs w/ OPT02 | |
| 111.1111 | 111.111044 | to | 111.111156 | 111.111094 to 111.111106 |
| 222.2222 | 222.222089 | to | 222.222311 | 222.222189 to 222.222211 |
| 333.3333 | 333.333133 | to | 333.333467 | 333.333283 to 333.333317 |
| 444.4444 | 444.444178 | to | 444.444622 | 444.444378 to 444.444422 |
| 555.5555 | 555.555222 | to | 555.555778 | 555.555472 to 555.555528 |
| 666.6666 | 666.666267 | to | 666.666933 | 666.666567 to 666.666633 |
| 777.7777 | 777.777311 | to | 777.778089 | 777.777661 to 777.777739 |
| 888.8888 | 888.888356 | to | 888.889244 | 888.888756 to 888.888844 |
| 999.9999 | 999.999400 | to | 1000.000400 | 999.999850 to 999.999950 |

4.2.1.8 Disconnect the electronic counter from the TI.

4.2.2 Output Level Accuracy Tests

4.2.2.1 Connect the calibrator sensor module input to the TI TRANS/-40 dB DUPLEX connector.

4.2.2.2 Adjust the TI Attenuator dial (or RF LEVEL) to 0 dBm, and set the TI for a frequency of 10 MHz.

4.2.2.3 Press the calibrator INSTR PRESET (Blue key, AUTOMATIC OPERATION key), ensure that the calibrator is tuned to approximately 10 MHz, and set the calibrator to measure RF POWER with log (dBm) display.

4.2.2.4 Verify that the calibrator indication is between -2.0 and +2.0 dBm.

4.2.2.5 Adjust the TI Attenuator dial (or RF LEVEL) to -5 dBm.

4.2.2.6 Set the calibrator to measure TUNED RF LEVEL with log (dBm) display, enter 39.9 SPCL, and press the CALIBRATE key.

4.2.2.7 Adjust the TI Attenuator dial (or RF LEVEL) to the following settings. At each setting, verify that the calibrator indication is within the tolerance limits listed.

| TI Attenuator Dial (or RF LEVEL) Setting (dBm) | Calibrator Tolerance Limits (dBm)* |
|--|--|
| -10 | -8.0 to -12.0 |
| -20 | -18.0 to -22.0 |
| -30 | -28.0 to -32.0 |
| -40 | -38.0 to -42.0 |
| -50 | -48.0 to -52.0 |
| -60 | -58.0 to -62.0 |
| -70 | -68.0 to -72.0 |
| -80 | -78.0 to -82.0 |
| -90 | -87.5 to -92.5 |
| -100 | -97.5 to -102.5 |

*Whenever the calibrator displays RECAL, press the calibrator CALIBRATE key.

4.2.2.8 Repeat steps 4.2.2.2 through 4.2.2.7 for TI frequency settings of 500 MHz and 999 MHz.

4.2.3 Residual FM Tests

4.2.3.1 Adjust the TI Attenuator dial (or RF LEVEL) to 0 dBm.

4.2.3.2 Set the TI MODULATION switch to FM 4, and for a RF frequency of 50 MHz.

4.2.3.3 Press the calibrator INSTR PRESET (Blue key, AUTOMATIC OPERATION key), ensure that the calibrator is tuned to approximately 50 MHz, and set the calibrator to measure FM Deviation. Activate the calibrator 300 HP and the 3 kHz LP filters.

4.2.3.4 Verify that the calibrator indication of FM deviation is less than 200 Hz.

4.2.3.5 Set the TI MODULATION switch to the FM 3, FM 2, and FM 1 positions, and at each position, verify that the calibrator indication of FM deviation is less than 50 Hz.

4.2.3.6 Repeat steps 4.2.3.2 through 4.2.3.5 for TI frequency settings of 850 MHz, except for a TI MODULATION switch setting of FM 4, verify that the calibrator indication of FM deviation is less than 250 Hz, and for TI MODULATION switch settings of FM 3, FM 2, and FM 1, verify that the calibrator indication of FM deviation is less than 200 Hz.

4.2.3.7 Disconnect the calibrator sensor module from the TI.

4.2.4 Spurious Signals Tests

4.2.4.1 Connect the spectrum analyzer RF input to the TI TRANS/-40 dB DUPLEX connector.

4.2.4.2 Set the TI for a RF frequency of 100 kHz.

4.2.4.3 Adjust the spectrum analyzer controls as necessary to conveniently view the TI signal.

4.2.4.4 Verify that the spectrum analyzer indicates that the harmonics of the TI signal are >25 dBc and non-harmonics are >40 dBc.

4.2.4.5 Set the TI for the following RF frequencies. At each setting, adjust the spectrum analyzer controls, as necessary, to conveniently view the TI signal and verify that the amplitude of any harmonic and non-harmonic is within the tolerance limits listed.

| TI RF Frequency Setting | Tolerance Limits | |
|----------------------------|------------------|---------------|
| | Harmonics | Non-Harmonics |
| 10 MHz | >25 dBc | >40 dBc |
| 500 MHz | " | " |
| 999 MHz | " | " |

4.2.4.6 Disconnect the spectrum analyzer from the TI.

4.3 DUPLEX GENERATOR TESTS

4.3.1 Frequency Accuracy Tests

4.3.1.1 Set the TI DUPLEX/SIMPLEX toggle switch to DUPLEX, and adjust the Attenuator dial (or RF LEVEL) to -10 dBm.

4.3.1.2 Connect the electronic counter input to the TI DUPLEX OUTPUT connector.

4.3.1.3 Set the TI for a RF frequency of 800 MHz.

4.3.1.4 Set the TI for an offset frequency of 1 MHz by pressing the following keypad sequence: OFFSET, 1, ., 0, 0, ENTER. Ensure that the TI LCD OFFSET MHz display indicates 1.00.

4.3.1.5 Verify that the electronic counter indication is between 800.99960 and 801.00040 MHz (800.99996 and 801.00004 MHz, TI's with option 02).

4.3.1.6 Using the method described in step 4.3.1.4, set the TI for the following offset frequencies. At each setting, verify that the electronic counter indicates within the tolerance limits listed.

| TI OFFSET Frequency Setting (MHz) | Electronic Counter Tolerance Limits (MHz) | | | | | |
|---|---|----|-----------|--------------|----|-----------|
| | TIs W/Out OPT02 | | | TIs w/ OPT02 | | |
| 1.11 | 811.10959 | to | 811.11041 | 811.10996 | to | 811.11004 |
| 33.33 | 833.32958 | to | 833.33042 | 833.32996 | to | 833.33004 |
| 49.99 | 849.98957 | to | 849.99043 | 849.98996 | to | 849.99004 |
| -1.00 | 798.99960 | to | 799.00040 | 798.99996 | to | 799.00004 |
| -11.11 | 788.88961 | to | 788.89039 | 788.88996 | to | 788.89004 |
| -33.33 | 766.66962 | to | 766.67038 | 766.66996 | to | 766.67004 |
| -49.99 | 750.00963 | to | 750.01038 | 750.00996 | to | 750.01004 |

4.3.1.7 Disconnect the electronic counter from the TI.

4.3.2 Output Level Accuracy Tests

4.3.2.1 Connect the calibrator sensor module input to the TI DUPLEX OUTPUT connector.

4.3.2.2 Set the TI for an offset frequency of +10 MHz by pressing the following keypad sequence: OFFSET, 1, 0, ., 0, 0, ENTER.

4.3.2.3 Adjust the TI Attenuator dial (or RF LEVEL) to 0 dBm.

4.3.2.4 Press the calibrator INSTR PRESET (Blue key, AUTOMATIC OPERATION key), ensure that the calibrator is tuned to approximately 810 MHz, and set the calibrator to measure RF POWER with log (dBm) display.

4.3.2.5 Verify that the calibrator indication is between -2.0 and +2.0 dBm.

4.3.2.6 Adjust the TI Attenuator dial (or RF LEVEL) to -5 dBm.

4.3.2.7 Set the calibrator to measure TUNED RF LEVEL with log (dBm) display, enter 39.9 SPCL, and press the CALIBRATE key.

4.3.2.8 Adjust the TI Attenuator dial (or RF LEVEL) to the following settings. At each setting, verify that the calibrator indication is within the tolerance limits listed.

| TI Attenuator Dial (or RF LEVEL) Setting (dBm) | Calibrator Tolerance Limits (dBm)* |
|--|--|
| -10 | -8.0 to -12.0 |
| -20 | -18.0 to -22.0 |
| -30 | -28.0 to -32.0 |
| -40 | -38.0 to -42.0 |
| -50 | -48.0 to -52.0 |
| -60 | -58.0 to -62.0 |
| -70 | -68.0 to -72.0 |
| -80 | -78.0 to -82.0 |
| -90 | -87.5 to -92.5 |
| -100 | -97.5 to -102.5 |

*Whenever the calibrator displays RECAL, press the calibrator CALIBRATE key.

4.3.2.9 Adjust the TI Attenuator dial (or RF LEVEL) to -10 dBm.

4.3.2.10 Disconnect the calibrator sensor module input from the TI DUPLEX OUTPUT connector and connect it to the TRANS/-40 dB DUPLEX connector.

4.3.2.11 Connect the 50 ohm load to the TI DUPLEX connector.

4.3.2.12 Adjust the TI Attenuator dial (or RF LEVEL) to the following settings. At each setting, verify that the calibrator indication is within the tolerance limits listed.

| TI Attenuator Dial (or RF LEVEL) Setting (dBm) | Calibrator Tolerance Limits (dBm) |
|--|---|
| -10 | -47.0 to -53.0 |
| -20 | -57.0 to -63.0 |
| -30 | -67.0 to -73.0 |
| -40 | -77.0 to -83.0 |
| -50 | -87.0 to -93.0 |
| -60 | -97.0 to -103.0 |

4.3.2.13 Disconnect the calibrator sensor module and the 50 ohm load from the TI.

4.3.2.14 Repeat steps 4.3.2.1 through 4.3.2.13 for a TI RF frequency setting of 10 MHz (20 MHz resulting output due to 10 MHz offset).

4.4 RECEIVER/MONITOR TESTS

NOTE

Throughout this test, adjust the TI INTENSITY and FOCUS controls as necessary for a proper display on the TI CRT.

4.4.1 Receiver Sensitivity Tests

4.4.1.1 Set the TI controls as follows:

| | |
|-----------------------------|--------------|
| MODULATION switch to | FM 1 |
| GEN/REC toggle switch to | REC |
| RF frequency to | 120.5000 MHz |
| FREQ ERROR switch to | 300 Hz |
| DISPLAY switch to | METER |
| ATTENUATOR toggle switch to | 0 dB |

4.4.1.2 Connect the signal generator RF output to the TI ANTENNA connector. Connect the signal generator 10 MHz reference output to the TI 10 MHz REF connector (rear panel).

4.4.1.3 Set the signal generator for a 120.5 MHz output at -50 dBm.

4.4.1.4 Note the frequency error indication on the TI CRT.

4.4.1.5 Adjust (decrease) the output level of the signal generator until a difference of 100 Hz is reached between the current frequency error indication on the TI CRT and the indication noted in step 4.4.1.4. Verify that the signal generator output level is ≤ -99 dBm.

NOTE

If the Receiver Sensitivity values are within 2 dB of their tolerance values, check the signal generator output levels in steps 4.4.1.5 and 4.4.1.7 using the calibrator. Use the calibrator indications in place of the signal generator output levels to verify the TI Receiver Sensitivity specifications.

4.4.1.6 Set the TI MODULATION switch to FM 2.

4.4.1.7 Adjust the output level of the signal generator until a difference of 100 Hz is reached between the current frequency error indication on the TI CRT and the indication noted in step 4.4.1.4. Verify that the signal generator output level is ≤ -90 dBm.

4.4.1.8 Disconnect the signal generator 10 MHz reference output from the TI, but leave the RF output connected to the TI ANTENNA connector.

4.4.2 Adjacent Channel Rejection Test

4.4.2.1 Set the TI controls as follows:

| | |
|--------------------------|-----------|
| DEV-PWR switch to | SIG |
| MODULATION switch to | FM 1 |
| DUPLEX/SIMPLEX switch to | SIMPLEX |
| GEN/REC switch to | REC |
| RF frequency to | 125.5 MHz |

4.4.2.2 Set the signal generator for a -90 dBm output at 125.5 MHz. Ensure that no signal generator modulation is turned on.

4.4.2.3 Adjust the signal generator output level for a TI CRT SIGNAL meter indication of 20.

4.4.2.4 Record the output level of the signal generator.

4.4.2.5 Set the TI for a RF frequency of 125.525 MHz.

4.4.2.6 Adjust the signal generator output level for a TI CRT SIGNAL meter indication of 20. Verify that the current signal generator output level is at least 25 dB greater than the level recorded in step 4.4.2.4.

NOTE

If the Adjacent Channel Rejection values are within 2 dB of their tolerance values, check the signal generator output levels in steps 4.4.2.4, 4.4.2.6, and 4.4.2.8 using the calibrator. Use the calibrator indications in place of the signal generator output levels to verify the TI Adjacent Channel Rejection specifications.

4.4.2.7 Set the TI for a RF frequency of 125.55 MHz.

4.4.2.8 Adjust the signal generator output level for a TI CRT SIGNAL meter indication of 20. Verify that the current signal generator output level is at least 40 dB greater than the level recorded in step 4.4.2.4.

4.4.2.9 Set the signal generator output level to minimum and disconnect the signal generator from the TI.

4.4.3 FM Demodulation Noise + Distortion Test

4.4.3.1 Set the TI MODULATION switch to FM 4, the DEV-PWR switch to 60 kHz (or 120 kHz, depending on the TI version), and set the TI for a RF frequency of 120.0 MHz.

4.4.3.2 Connect the signal generator RF output through the power divider to the calibrator sensor module input and the TI ANTENNA connector.

4.4.3.3 Set the signal generator for a -5 dBm output at 120.0 MHz, with no modulation activated.

4.4.3.4 Press the calibrator INSTR PRESET (Blue key, AUTOMATIC OPERATION key), ensure that the calibrator is tuned to approximately 120.0 MHz, and set the calibrator to measure TUNED RF LEVEL with log (dBm) display, enter 39.9 SPCL, and press the CALIBRATE key.

4.4.3.5 Reduce the signal generator output level until the calibrator displays RECAL, and then press the calibrator CALIBRATE key. Reduce the signal generator output level again until the calibrator displays RECAL, and then press the calibrator CALIBRATE key.

4.4.3.6 Set the signal generator output level for an approximate -5 dBm indication on the calibrator.

4.4.3.7 Set the calibrator for FM modulation measurements, and activate the calibrator 300 Hz HP FILTER and the 3 kHz LP FILTER.

4.4.3.8 Set the signal generator for FM modulation at a 1 kHz rate, and adjust the FM deviation for a 25.0 kHz deviation indication on the calibrator. Deactivate the FM modulation of the signal generator, but do not change the rate and deviation settings.

4.4.3.9 Set the calibrator to measure TUNED RF LEVEL with a log (dBm) display, and then set the signal generator output level for a -50.0 dBm indication on the calibrator. Activate the modulation of the signal generator.

4.4.3.10 Connect the TI DEMOD OUTPUT connector to the distortion analyzer input.

4.4.3.11 Set the distortion analyzer for distortion measurements and verify that the distortion indication is less than 2%.

4.4.3.12 Disconnect the distortion analyzer from the TI.

4.4.4 Deviation Analog Meter and Digital Deviation Display (CRT) Tests

4.4.4.1 Set the TI controls as follows:

| | |
|--------------------------|----------|
| DEV/PWR toggle switch to | AVG (up) |
| DEV-PWR switch to | 6 kHz |
| MODULATION switch to | FM 1 |

4.4.4.2 Deactivate the FM modulation of the signal generator and set the signal generator output level for an approximate -5 dBm indication on the calibrator, and then set the calibrator for FM modulation measurements.

4.4.4.3 Activate the FM modulation of the signal generator and adjust the signal generator FM deviation for a 1.0 kHz deviation indication on the calibrator. Deactivate the FM modulation of the signal generator, but do not change the rate and deviation settings.

4.4.4.4 Set the calibrator to measure TUNED RF LEVEL with log (dBm) display, and then set the signal generator output level for a -50.0 dBm indication on the calibrator. Activate the FM modulation of the signal generator.

4.4.4.5 Verify that the TI MODULATION meter indicates between 0.9 and 1.1 kHz FM deviation.

4.4.4.6 Set the TI DISPLAY switch to SCOPE, and the DEV-VERT switch to .5 kHz/DIV.

4.4.4.7 Verify that the TI CRT deviation display (peak-peak) is between 3.6 and 4.4 divisions in width (deviation of 0.9 to 1.1 kHz peak).

4.4.4.8 Set the TI DISPLAY switch to METER, and the MODULATION switch to FM 2.

4.4.4.9 Activate the calibrator 15 kHz LP FILTER. Repeat steps 4.4.4.2 through 4.4.4.4, except set the signal generator for a modulation rate of 6 kHz and the FM deviation to 2.0 kHz, as indicated by the calibrator.

4.4.4.10 Verify that the TI CRT digital deviation display indicates between 1.940 and 2.060 kHz FM deviation, and verify that the TI MODULATION meter indicates between 1.7 and 2.3 kHz FM deviation.

4.4.4.11 Activate the calibrator 3 kHz LP FILTER. Repeat steps 4.4.4.2 through 4.4.4.4, except set the signal generator for a modulation rate of 1 kHz and the FM deviation to 5.0 kHz, as indicated by the calibrator.

4.4.4.12 Verify that the TI MODULATION meter indicates between 4.7 and 5.3 kHz FM deviation.

4.4.4.13 Set the TI DISPLAY switch to SCOPE, and the DEV-VERT switch to 2 kHz/DIV.

4.4.4.14 Verify that the TI CRT deviation display (peak-peak) is between 4.5 and 5.5 divisions in width (deviation of 4.5 to 5.5 kHz peak).

4.4.4.15 Set the TI DISPLAY switch to METER, the DEV-PWR switch to 20 kHz, and the MODULATION switch to FM 3.

4.4.4.16 Deactivate the calibrator 3 kHz LP FILTER. Repeat steps 4.4.4.2 through 4.4.4.4, except set the signal generator for a modulation rate of 10 kHz and the FM deviation to 8.0 kHz, as indicated by the calibrator.

4.4.4.17 Verify that the TI CRT digital deviation display indicates between 7.760 and 8.240 kHz FM deviation, and verify that the TI MODULATION meter indicates between 7.0 and 9.0 kHz FM deviation.

4.4.4.18 Activate the calibrator 3 kHz LP FILTER. Repeat steps 4.4.4.2 through 4.4.4.4, except set the signal generator for a modulation rate of 1 kHz and the FM deviation to 15.0 kHz, as indicated by the calibrator.

4.4.4.19 Verify that the TI MODULATION meter indicates between 13.0 and 17.0 kHz FM deviation.

4.4.4.20 Set the TI DISPLAY switch to SCOPE, and the DEV-VERT switch to to 5 kHz/DIV.

4.4.4.21 Verify that the TI CRT deviation display (peak-peak) is between 5.4 and 6.6 divisions in width (deviation of 13.5 to 16.5 kHz peak).

4.4.4.22 Set the TI DISPLAY switch to METER, the DEV-PWR switch to 60 kHz (or 120 kHz, depending on the TI version), and the MODULATION switch to FM 4.

4.4.4.23 Repeat steps 4.4.4.2 through 4.4.4.4, except set the signal generator for a modulation rate of 1 kHz and the FM deviation to 20.0 kHz, as indicated by the calibrator.

4.4.4.24 Verify that the TI MODULATION meter indicates between 17.0 and 23.0 kHz FM deviation.

4.4.4.25 Repeat steps 4.4.4.2 through 4.4.4.4., except set the signal generator for a modulation rate of 1 kHz and the FM deviation to 50.0 kHz, as indicated by the calibrator.

4.4.4.26 Verify that the TI MODULATION meter indicates between 47.0 and 53.0 kHz FM deviation.

4.4.4.27 Set the TI DISPLAY switch to SCOPE, and the DEV-VERT switch to to 20 kHz/DIV.

4.4.4.28 Verify that the TI CRT deviation display (peak-peak) is between 4.5 and 5.5 divisions in width (deviation of 45 to 55 kHz peak).

4.4.4.29 Turn off the signal generator FM deviation.

4.4.5 AM Modulation Analog Meter and Digital AM Modulation Display (CRT) Tests

4.4.5.1 Set the TI controls as follows:

| | |
|--------------------------|-------------|
| DEV/PWR toggle switch to | PEAK (down) |
| DEV-PWR switch to | 2% X 10 |
| MODULATION switch to | AM 1 |
| DISPLAY switch to | METER |

4.4.5.2 Set the signal generator output level for an approximate -5 dBm indication on the calibrator, and then set the calibrator for AM modulation measurements.

4.4.5.3 Adjust the signal generator controls for a modulation rate of 1 kHz, and adjust the AM depth for a 15.0% indication on the calibrator.

4.4.5.4 Set the calibrator to measure TUNED RF LEVEL with log (dBm) display, and then set the signal generator output level for a -50.0 dBm indication on the calibrator.

4.4.5.5 Verify that the TI CRT digital AM modulation display indicates between 12.2% and 17.8% AM depth, and verify that the TI MODULATION meter indicates between 13.0% and 17.0% AM depth.

4.4.5.6 Set the TI DEV-PWR switch to 6% X 10.

4.4.5.7 Repeat steps 4.4.5.2 through 4.4.5.4, except set the signal generator for a modulation rate of 1 kHz and the AM depth to 30.0%, as indicated by the calibrator.

4.4.5.8 Verify that the TI CRT digital Am modulation display indicates between 26.5% and 33.5% AM depth, and verify that the TI MODULATION meter indicates between 25% and 35% AM depth.

4.4.5.9 Repeat steps 4.4.5.2 through 4.4.5.4, except set the signal generator for a modulation rate of 1 kHz and the AM depth to 50.0%, as indicated by the calibrator.

4.4.5.10 Verify that the TI CRT digital AM modulation display indicates between 45.5% and 54.5% AM depth, and verify that the TI MODULATION meter indicates between 43% and 57% AM depth.

4.4.5.11 Set the TI MODULATION switch to AM 2 and the DEV-PWR switch to 20% X 10.

4.4.5.12 Repeat steps 4.4.5.2 through 4.4.5.4, except set the signal generator for a modulation rate of 1 kHz and the AM depth to 80.0%, as indicated by the calibrator.

4.4.5.13 Verify that the TI CRT digital AM modulation display indicates between 56% and 104% Am depth, and verify that the TI MODULATION meter indicates between 64% and 96% AM depth.

4.4.5.14 Adjust the TI VOLUME control cw and verify the presence of a tone from the TI Speaker. Adjust the TI VOLUME control fully ccw.

4.4.5.15 Set the signal generator output level to minimum, but do not disconnect the equipment from the TI.

4.5 SPECTRUM ANALYZER TESTS

NOTE

Throughout this test, adjust the TI INTENSITY and FOCUS controls as necessary for a proper display on the TI CRT.

4.5.1 Spectrum Analyzer Linearity Tests

4.5.1.1 Set the TI controls as follows:

| | |
|-----------------------------|-------|
| ATTENUATOR toggle switch to | 40 dB |
| DISPLAY switch to | ANALY |

4.5.1.2 Set the signal generator for a 0 dBm output at 120.0 MHz, with no modulation activated.

4.5.1.3 Set the calibrator to measure TUNED RF LEVEL with log (dBm) display.

4.5.1.4 Set the TI ATTENUATOR toggle switch to 0 dB.

4.5.1.5 Adjust the output level of the signal generator such that the signal displayed on the TI CRT is exactly on the -40 dB graticule.

4.5.1.6 Activate the calibrator SET REF function by pressing the BLUE and ZERO (SET REF) keys. Ensure that the calibrator display is 0.00 ± 0.01 dB.

4.5.1.7 Adjust the signal generator output level such that the signal displayed on the TI CRT is exactly aligned with the following graticules. At each setting, verify that the calibrator reference indication is within the tolerance limits listed.

| TI Graticule Setting (dB) | Calibrator Reference Tolerance Limits (dB) |
|---------------------------|--|
| -30 | +8.0 to +12.0 |
| -50 | -8.0 to -12.0 |
| -60 | -18.0 to -22.0 |
| -70 | -28.0 to -32.0 |
| -80 | -38.0 to -42.0 |
| -90 | -48.0 to -52.0 |

4.5.2 Antenna Attenuator Tests

4.5.2.1 Adjust the output level of the signal generator such that the signal displayed on the TI CRT is exactly on the -50 dB graticule.

4.5.2.2 Activate the calibrator SET REF function by pressing the BLUE and ZERO (SET REF) keys. Ensure that the calibrator display is 0.00 ± 0.01 dB.

4.5.2.3 Set the TI ATTENUATOR toggle switch to 20 dB.

4.5.2.4 Adjust the output level of the signal generator such that the signal displayed on the TI CRT is exactly on the -50 dB graticule.

4.5.2.5 Verify that the calibrator reference indication is between +18.0 and +22.0 dB.

4.5.2.6 Set the TI ATTENUATOR toggle switch to 40 dB.

4.5.2.7 Adjust the output level of the signal generator such that the signal displayed on the TI CRT is exactly on the -50 dB graticule.

4.5.2.8 Verify that the calibrator reference indication is between +38.0 and +42.0 dB.

4.5.2.9 Set the signal generator output level to minimum, and disconnect the equipment from the TI.

4.5.3 Spectrum Analyzer Dispersion Tests

4.5.3.1 Set the TI controls as follows:

| | |
|-----------------------------|-----------|
| ATTENUATOR toggle switch to | 0 dB |
| ANALY DISPR switch to | 1 kHz/DIV |

4.5.3.2 Connect the signal generator RF output to the TI ANTENNA connector.

4.5.3.3 Set the signal generator for a -50 dBm output at 120.0 MHz.

4.5.3.4 Adjust the TI Horizontal Centering Adjustment control (located below lower right portion of the TI CRT) as necessary to align the displayed signal with the center vertical graticule.

4.5.3.5 Set the signal generator frequency to 120.004 MHz and verify that the TI CRT display indicates that the signal shifted from 3.7 to 4.3 major divisions to the right of the center vertical graticule.

4.5.3.6 Set the signal generator frequency to 119.996 MHz and verify that the TI CRT display indicates that the signal shifted from 3.7 to 4.3 major divisions to the left of the center vertical graticule.

4.5.3.7 Set the TI ANALY DISPR switch and the signal generator frequency controls for the following settings. At each setting, verify that the TI CRT displayed signal is located within the tolerance limits listed to the left and right of the center vertical graticule.

NOTE

After setting the TI ANALY DISPR switch to each setting, set the signal generator frequency to 120.0 MHz and ensure that the TI CRT displayed signal is aligned with the center vertical graticule. If not, adjust the TI Horizontal Centering Adjustment control as necessary to align the displayed signal with the center vertical graticule and continue with the tests.

| TI ANALY DISPR Switch Setting | Signal Generator Frequency Setting | TI CRT Signal Location* |
|----------------------------------|---------------------------------------|----------------------------|
| 2 kHz/DIV | 120.008 MHz | 3.7 to 4.3 div right |
| ” | 119.992 ” | ” left |
| 10 kHz/DIV | 120.040 ” | ” right |
| ” | 119.960 ” | ” left |
| 20 kHz/DIV | 120.080 ” | ” right |
| ” | 119.920 ” | ” left |
| .1 MHz/DIV | 120.400 ” | ” right |
| ” | 119.600 ” | ” left |
| .2 MHz/DIV | 120.800 ” | ” right |
| ” | 119.200 ” | ” left |
| .5 MHz/DIV | 122.000 ” | ” right |
| ” | 118.000 ” | ” left |
| 1 MHz/DIV | 124.000 ” | ” right |
| ” | 116.000 ” | ” left |
| 2 MHz/DIV | 128.000 ” | ” right |
| ” | 112.000 ” | ” left |
| 5 MHz/DIV | 140.000 ” | ” right |
| ” | 100.000 ” | ” left |
| 10 MHz/DIV | 160.000 ” | ” right |
| ” | 80.000 ” | ” left |

*Referenced to TI CRT center vertical graticule.

4.5.3.8 Set the signal generator output level to minimum, and disconnect the equipment from the TI.

4.6 OSCILLOSCOPE TESTS

NOTE

Throughout this test, adjust the TI INTENSITY and FOCUS controls as necessary for a proper display on the TI CRT.

4.6.1 Set the TI controls as follows:

| | |
|--------------------|-----------|
| DEV-VERT switch to | .01 V/DIV |
| DISPLAY switch to | SCOPE |

4.6.2 Connect the ac calibrator output to the TI SCOPE/SINAD INPUT connector.

4.6.3 Set the ac calibrator for a 50 mV p-p (17.68 mV rms) output at 1 kHz.

4.6.4 Adjust the TI VERT POS and HORIZ POS controls as necessary to center the signal on the CRT.

4.6.5 Set the TI DEV-VERT switch and ac calibrator output level to the following settings. At each setting, verify that the TI CRT display indicates that the signal peak-to-peak amplitude is within the tolerance limits listed.

| TI DEV-VERT Switch Setting | AC Calibrator Output Setting | Tolerance Limits |
|-------------------------------|---------------------------------|----------------------|
| .01 V/DIV | 50 mV p-p (17.68 mV rms) | 4.5 to 5.5 divisions |
| .1 " | 500 " (176.8 ") | " |
| 1 " | 5 V p-p (1.768 V rms) | " |
| 10 " | 50 " (17.68 ") | " |

4.6.6 Adjust the TI VERT VERNIER control fully ccw, and verify that the CRT signal is less than 2.5 divisions peak-to-peak in amplitude.

4.6.7 Set the ac calibrator output level to minimum, and disconnect the ac calibrator from the TI.

4.6.8 Connect the function generator to the TI SCOPE/SINAD INPUT connector.

4.6.9 Set the TI controls as follows:

| | |
|-------------------------|----------------|
| DEV-VERT switch to | 1 V/DIV |
| VERT VERNIER control to | fully cw (CAL) |
| HORIZ switch to | .01 ms/DIV |

4.6.10 Set the function generator for a 100 kHz output at 2 V p-p (0.707 V rms).

4.6.11 Verify that the TI CRT display indicates 10 \pm 2 full cycles of the signal.

4.6.12 Set the function generator frequency to 10 kHz, and set the TI HORIZ switch to .1 ms/DIV.

4.6.13 Verify that the TI CRT display indicates 10 \pm 2 full cycles of the signal.

4.6.14 Set the function generator frequency to 1 kHz, and set the TI HORIZ switch to 1 ms/DIV.

4.6.15 Verify that the TI CRT display indicates 10 \pm 2 full cycles of the signal.

4.6.16 Set the function generator frequency to 100 Hz, and set the TI HORIZ switch to 10 ms/DIV.

4.6.17 Verify that the TI CRT display indicates 10 \pm 2 full cycles of the signal.

4.6.18 Disconnect the function generator from the TI.

4.7 DUAL TONE GENERATOR TESTS

4.7.1 Dual Tone Generator Frequency Accuracy and Output Level Tests

4.7.1.1 Set the TI controls as follows:

| | |
|-----------------------------------|-----------|
| HORIZ switch to | 10 ms/DIV |
| MODULATION switch to | FM 4 |
| Tone 1 frequency to | 0000.0 Hz |
| TONE 1 control to | fully ccw |
| Tone 2 frequency to | 0000.0 Hz |
| TONE 2 control to | fully ccw |
| INT TONE/RCVR toggle switch to | INT TONE |
| DEV-VERT switch to | 2 kHz/DIV |
| DISPLAY switch to | METER |
| DEV-PWR switch to | 60% X 10 |
| GEN/REC switch to | GEN |
| Tone 1 FM/OFF/AM toggle switch to | FM |
| Tone 2 FM/OFF/AM toggle switch to | FM |

4.7.1.2 Connect the equipment as shown in Figure 2.

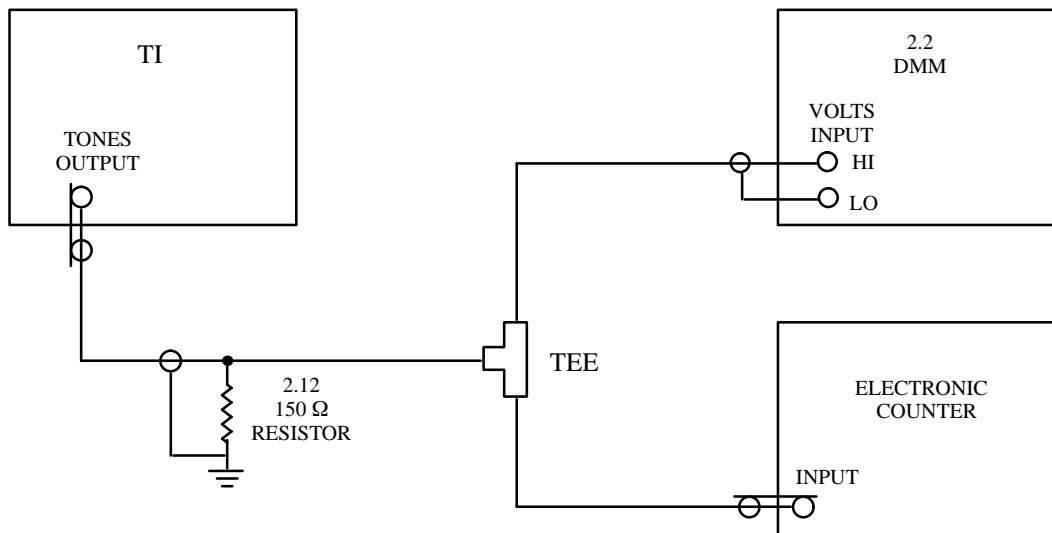

Figure 2. Dual Tone Generator Test Configuration

4.7.1.3 Set the DMM for autoranging ac voltage measurements, and set the electronic counter for frequency measurements with 1 MΩ input impedance.

4.7.1.4 Set the TI Tone 1 frequency to 20.0 Hz, and adjust the TONE 1 control fully cw.

4.7.1.5 Verify that the DMM indication is ≥ 2.5 V rms.

4.7.1.5.1 Set the TI Tone 1 control to mid-range.

4.7.1.6 Verify that the electronic counter indication is between 19.998 and 20.002 Hz, and verify that the TI CRT Demod Count reading is between 18 and 22 Hz.

4.7.1.7 Repeat steps 4.7.1.4 through 4.7.1.6 for the following TI Tone 1 frequency settings, except verify that the electronic counter and TI CRT Demod Count indications are within the tolerance limits listed.

| TI Tone 1 Frequency Setting (Hz) | Electronic Counter Tolerance Limits (Hz) | TI CRT Demod Count Tolerance Limits |
|--|--|---|
| 100.0 | 99.99 to 100.01 | 98 to 102 Hz |
| 1000.0 | 999.90 to 1000.10 | 998 to 1002 " |
| 5000.0 | 4999.50 to 5000.50 | 4998 to 5002 " |
| 10000 | 9999.00 to 10001.00 | 9998 to 10002 " |
| 20000 | 19998.00 to 20002.00 | 19998 to 20002 " |

4.7.1.8 Adjust the TI TONE 1 control fully ccw, and set the Tone 1 frequency to 0000.0 Hz.

4.7.1.9 Repeat steps 4.7.1.4 through 4.7.1.8, except use Tone 2 (or TONE 2) wherever Tone 1 (or TONE 1) is called out.

4.7.2 Dual Tone Generator Distortion Tests

4.7.2.1 Replace the DMM with the distortion analyzer, and ensure that the distortion analyzer is set for distortion measurements.

4.7.2.2 Set the TI Tone 1 frequency to 1000.0 Hz, and adjust the TONE 1 control fully cw.

4.7.2.3 Verify that the distortion analyzer indicates that the distortion is less than 0.7%.

4.7.2.4 Set the TI Tone 1 frequency to 10000 Hz.

4.7.2.5 Verify that the distortion analyzer indicates that the distortion is less than 0.7%.

4.7.2.6 Set the TI Tone 1 frequency to 20000 Hz.

4.7.2.7 Verify that the distortion analyzer indicates that the distortion is less than 0.7%.

4.7.2.8 Set the TI Tone 1 frequency to 50.0 Hz.

4.7.2.9 Verify that the distortion analyzer indicates that the distortion is less than 2%.

4.7.2.10 Adjust the TI TONE 1 control fully ccw, and set the Tone 1 frequency to 0000.0 Hz.

4.7.2.11 Repeat steps 4.7.2.2 through 4.7.2.10, except use Tone 2 (or TONE 2) wherever Tone 1 (or TONE 1) is called out.

4.7.2.12 Disconnect the equipment from the TI.

4.8 FREQUENCY ERROR METER TESTS

4.8.1 Set the TI controls as follows:

| | |
|-----------------------------------|---------------------|
| DUPLEX/SIMPLEX toggle switch to | SIMPLEX |
| GEN/REC toggle switch to | REC |
| RF Frequency to | 120.0000 MHz |
| DISPLAY to | METER |
| MODULATION switch to | FM 2 |
| ANALY DISPR switch to | 1 MHz/DIV (or less) |
| Tone 1 FM/OFF/AM toggle switch to | OFF |
| Tone 2 FM/OFF/AM toggle switch to | OFF |

4.8.2 Connect the signal generator RF output to the TI ANTENNA connector. Connect the signal generator 10 MHz reference output to the TI 10 MHz REF connector (rear panel).

4.8.3 Set the TI FREQ ERROR switch to 10 kHz.

4.8.4 Set the signal generator for a 120.005000 MHz output at -40 dBm.

4.8.5 Verify that the TI FREQ ERROR meter indication is between +0.4 and +0.6 (meter deflection is to the right).

4.8.6 Set the signal frequency controls for a 119.995000 MHz output.

4.8.7 Verify that the TI FREQ ERROR meter indication is between -0.4 and -0.6 (meter deflection is to the left).

4.8.8 Repeat steps 4.8.3 through 4.8.7 for the following TI FREQ ERROR switch settings and their corresponding signal generator frequency settings (using the first signal generator frequency setting when repeating step 4.8.4, and the second signal generator frequency setting when repeating step 4.8.6).

| TI FREQ ERROR Switch Setting | Signal Generator Frequency Setting |
|---------------------------------|---------------------------------------|
| 1 kHz | 120.000500 MHz |
| ” | 119.999500 ” |
| 100 Hz | 120.000050 ” |
| ” | 119.999950 ” |

4.8.9 Set the TI FREQ ERROR switch to 3 kHz.

4.8.10 Set the signal generator frequency control for a 120.002000 MHz output.

4.8.11 Verify that the TI FREQ ERROR meter indication is between +1.9 and +2.1.

4.8.12 Set the signal generator frequency controls for a 119.99800 MHz output.

4.8.13 Verify that the TI FREQ ERROR meter indication is between -1.9 and -2.1.

4.8.14 Repeat steps 4.8.9 through 4.8.13 for the following TI FREQ ERROR switch settings and their corresponding signal generator frequency settings (using the first signal generator frequency setting when repeating step 4.8.10, and the second signal generator frequency setting when repeating step 4.8.12).

| TI FREQ ERROR Switch Setting | Signal Generator Frequency Setting |
|------------------------------|------------------------------------|
| 300 Hz | 120.000200 MHz |
| ” | 119.999800 ” |
| 30 ” | 120.000020 ” |
| ” | 119.999980 ” |

4.8.15 Set the signal generator output to minimum, and disconnect the equipment from the TI.

4.9 INTERNAL SINAD METER TEST

4.9.1 Set the TI controls as follows:

- | | |
|-----------------------------------|-----------|
| DEV-PWR switch to | SINAD |
| DUPLEX/SIMPLEX switch to | SIMPLEX |
| Tone 1 FM/OFF/AM toggle switch to | FM |
| Tone 1 Frequency to | 1000.0 Hz |
| TONE 1 control to | fully ccw |
| Tone 2 FM/OFF/AM toggle switch to | FM |
| Tone 2 Frequency to | 1800.0 |
| TONE 2 control to | fully ccw |
| ATTENUATOR toggle switch to | 0 dB |
| DISPLAY switch to | METER |

4.9.2 Connect the equipment as shown in Figure 3.

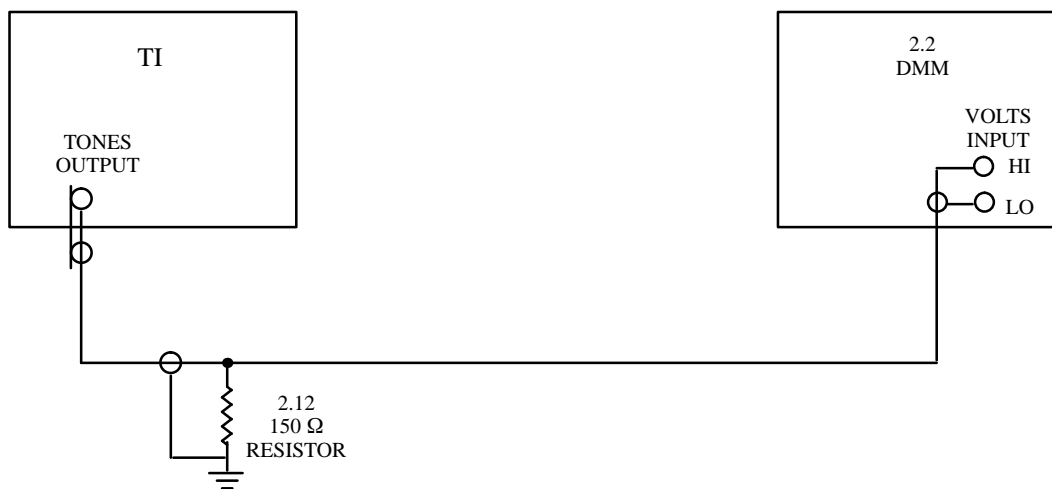

Figure 3. SINAD Preliminary Test Configuration

4.9.3 Set the DMM for autoranging ac voltage measurements.

4.9.4 Adjust the TI TONE 1 control fully cw and record the DMM indication.

4.9.5 Adjust the TI TONE 1 control fully ccw.

4.9.6 Adjust the TI TONE 2 control cw until the DMM indication is 1/4 of the DMM indication recorded in step 4.9.4.

4.9.7 Disconnect the equipment from the TI, and then connect the TI TONES OUTPUT connector to the TI SCOPE/SINAD INPUT connector.

4.9.8 Adjust the TI TONE 1 control fully cw.

4.9.9 Verify that the TI MODULATION meter display indicates 12 ± 1.0 dB on the SINAD scale, and verify that the TI CRT SINAD reading is 12 ± 1.0 dB.

4.9.10 Adjust the TI TONE 1 and TONE 2 controls fully ccw and disconnect the cable between the TONES OUTPUT and SCOPE/SINAD INPUT connectors.

4.10 POWER MONITOR TESTS

WARNING

POWER LEVELS DANGEROUS TO HUMAN LIFE MAY BE PRESENT IN THIS PROCEDURE. TURN OFF POWER TO THE TEST SETUP BEFORE CONNECTING OR DISCONNECTING ANY EQUIPMENT.

4.10.1 Set the TI controls as follows:

| | |
|-----------------------------------|----------|
| DEV-PWR switch to | 15 WATTS |
| DISPLAY switch to | METER |
| DEV-PWR toggle switch to | AVG (up) |
| Tone 1 FM/OFF/AM toggle switch to | OFF |
| Tone 2 FM/OFF/AM toggle switch to | OFF |

4.10.2 Connect the equipment as shown in Figure 4. Ensure that the signal generator output level is set to minimum.

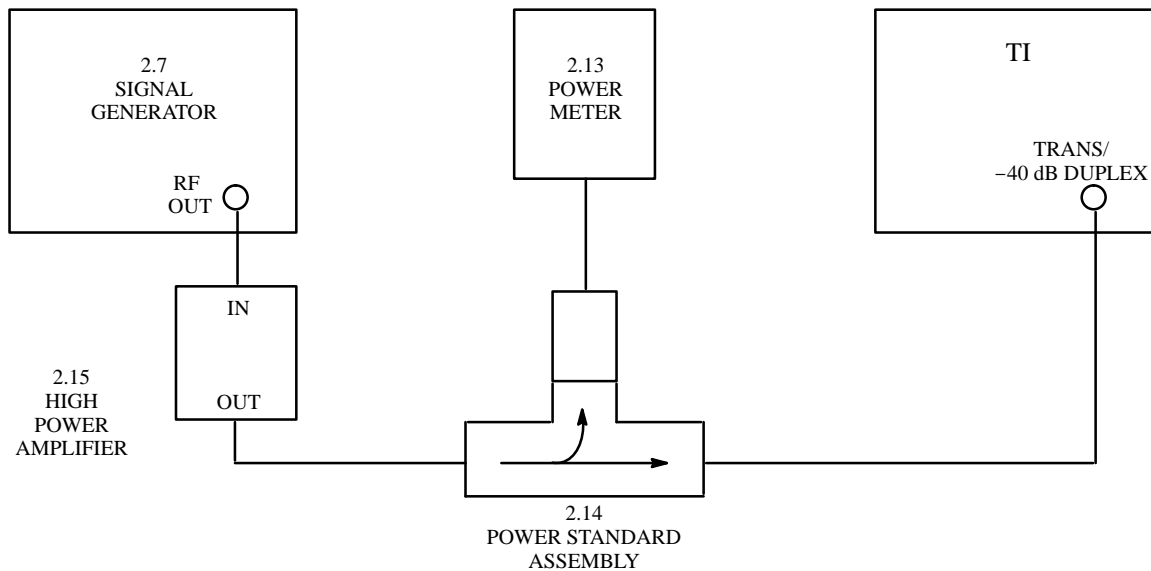

Figure 4. Power Monitor Test Configuration Using Power Standard Assembly

4.10.3 Set the signal generator frequency to 30 MHz.

4.10.4 Adjust the signal generator output level for a 10 W TI MODULATION meter power indication. Set the power meter range switch for an on-scale indication, if necessary.

4.10.5 Verify that the adjusted power meter indication (taking the power standard assembly coupling factor into account) is between 8.85 and 11.15 Watts. Set the note following this step.

NOTE

To get the adjusted power meter indication:

- (1) First, if the power standard assembly is being used, set the power meter calibration factor switch to 100; otherwise, if the power standard assembly is not being used, set the power meter calibration factor switch to the appropriate setting for the test frequency as found on the thermistor mount Report of Calibration.
- (2) Find the power standard assembly (or directional coupler) Report of Calibration coupling factor at the test frequency.
- (3) Convert the power standard assembly (or directional coupler) log coupling factor to a linear power ratio value by referring to the following equation:

$$\text{Linear power ratio} = 10^{(\text{Log coupling factor}/10)}$$

- (4) Multiply the current power meter indication by the power ratio determined to get the adjusted power meter setting.

Example:

- (a) Power meter calibration factor switch set appropriately.
- (b) Power standard assembly (or directional coupler) Report of Calibration coupling factor for test frequency is 45.8 dB.

(c) Per equation in (3) above, the conversion of the log coupling factor to a linear power ratio results in 38,018.94.

(d) Multiply current power meter indication of 0.28 mW by the power ratio of 38,018.94 = 10.65 Watts.

4.10.6 Adjust the signal generator output level for a 10 W TI CRT power indication. Set the power meter range switch for an on-scale indication, if necessary.

4.10.7 Verify that the adjusted power meter indication (taking the power standard assembly coupling factor into account) is between 8.85 and 11.15 Watts. Set the note following step 4.10.5.

4.10.8 Set the TI DEV-PWR switch to 150 WATTS.

4.10.9 Adjust the signal generator output level for a 80 W TI MODULATION meter power indication. Set the power meter range switch for an on-scale indication, if necessary.

4.10.10 Verify that the adjusted power meter indication (taking the power standard assembly coupling factor into account) is between 69.9 and 90.1 Watts. See the note following step 4.10.5.

4.10.11 Adjust the signal generator output level for a 80 W TI CRT power indication. Set the power meter range switch for an on-scale indication, if necessary.

4.10.12 Verify that the adjusted power meter indication (taking the power standard assembly coupling factor into account) is between 69.9 and 90.1 Watts. See the note following step 4.10.5.

4.10.13 Adjust the signal generator output level to minimum, set the signal generator frequency to 400 MHz.

4.10.14 Repeat steps 4.10.9 through 4.10.13.

4.10.15 Set the TI DEV-PWR switch to 15 WATTS.

4.10.16 Repeat steps 4.10.4 through 4.10.7.

4.10.17 Adjust the signal generator output level to minimum, set the signal generator frequency to 800 MHz.

4.10.18 Remove the power standard assembly and high power amplifier from the test setup and replace it with the directional coupler, thermistor mount, and low power amplifier as shown in Figure 5.

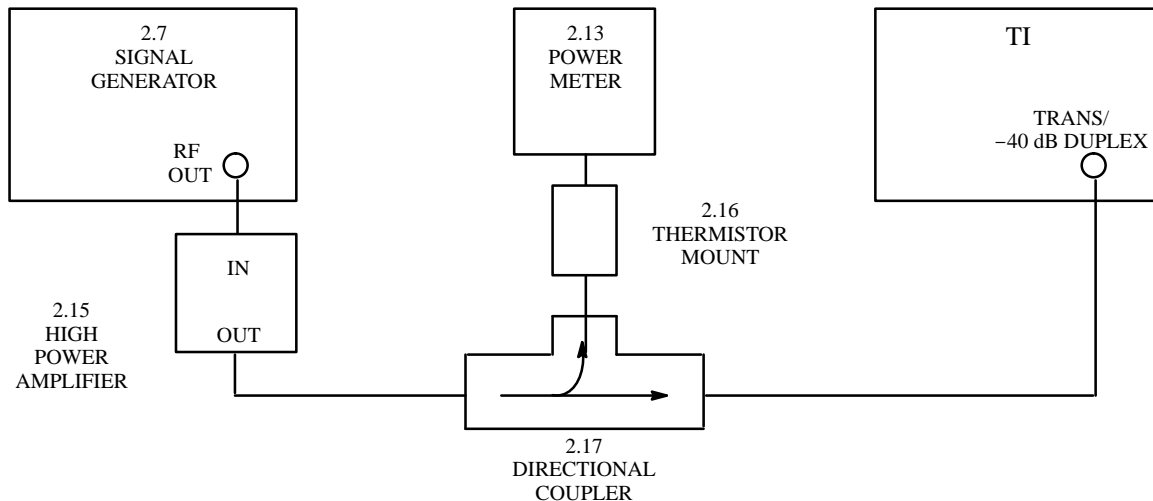

Figure 5. Power Monitor Test Configuration Using Directional Coupler

4.10.19 Adjust the signal generator output level for a 3 W TI MODULATION meter power indication. Set the power meter range switch for an on-scale indication, if necessary.

4.10.20 Verify that the adjusted power meter indication (taking the directional coupler coupling factor into account) is between 2.04 and 3.96 Watts. Set the note following step 4.10.5.

4.10.21 Adjust the signal generator output level for a 3 W TI CRT power indication. Set the power meter range switch for an on-scale indication, if necessary.

4.10.22 Verify that the adjusted power meter indication (taking the directional coupler coupling factor into account) is between 2.04 and 3.96 Watts. See the note following step 4.10.5.

4.10.23 Adjust the signal generator output level to minimum, set the signal generator frequency to 850 MHz.

4.10.24 Repeat steps 4.10.19 through 4.10.22 for a test frequency of 850 MHz, except verify that the adjusted power meter indication is between 2.34 and 3.66 Watts for the 3 Watt tests.

4.10.25 Set the signal generator output level to minimum, and disconnect the equipment from the TI.

NOTE

If the TI is not equipped with an IEEE bus (option 01), skip to step 4.11.11; otherwise, proceed with subsection 4.11.

4.11 IEEE BUS TEST (TI'S W/OPTION 01 ONLY)

4.11.1 Connect the TI rear panel IEEE-488 connector to the instrument controller using the appropriate cable.

4.11.2 Insert the diskette into the instrument controller, press the controller restart button, and sequence as per the controller CRT instructions.

NOTE

The 1722A/AP Controller CRT is touch sensitive. Program accordingly.

NOTE

There are some minor differences between the programming steps required for using version 2 or version 3 (or 4) of the IEEE Bus tester program (NAVAIR 17-20MSYS-036D). The following procedure steps contain instructions written towards using version 2 or version 3 (or 4). Use the appropriate series of steps starting at 4.11.3 and 4.11.4 corresponding to the version available of the IEEE Bus tester program.

4.11.3 IEEE Bus Tester Instructions, Version 2

4.11.3.1 On the controller, when the model number display appears, enter the TI Model Number.

4.11.3.2 On the controller, when the Instrument Type display appears, enter Talker and Listener.

4.11.3.3 Skip to step 4.11.5.

4.11.4 IEEE Bus Tester Instructions, Version 3 (or 4)

4.11.4.1 On the controller, when the model number display appears, select the TI model number, if it is provided, and then select the End Selections function.

4.11.4.2 Following the controller CRT instructions, sequence through the bus address search function, and enter the TI Model Number.

4.11.5 On the controller, when the command display appears, enter RFF=123.4567 (123.4567 MHz).

4.11.6 On the controller, when Type of Command appears, enter Listen.

4.11.7 Verify that the TI LCD display indicates that the TI is set for a RF frequency of 123.4567 MHz, and that the controller CRT display of Command indicates the program command entered in step 4.11.5.

4.11.8 On the controller, go to the command display, enter RFL?, and when Type of Command appears, enter Talk.

4.11.9 Verify that the next controller CRT display of Data Received indicates the TI RF LEVEL setting, and that the CRT display of Command indicates the program command entered in step 4.11.8.

4.11.10 Press the controller abort switch, retrieve the diskette, and disconnect the equipment from the TI.

4.11.11 Unless other measurements are to be performed, turn all power switches to off or standby, and disconnect the equipment from the TI.

4.11.12 Affix a special calibration label to the TI stating that the FM Digital Deviation Display (CRT) accuracy was tested only to a 3:1 test accuracy ratio (TAR).

CALIBRATION CHECKLIST

TEST INST (S) IFR Inc. FM/AM-1500, FM/AM-1500OPT01,02, or FM/AM-1500OPT02
 Communications Service Monitor

| PROC. NO. | NA 17-20AQ-289 | MFG. | MODEL | | SER. NO. | |
|---------------------------------|---|----------------|------------------|-------------------|-------------------------|-------------------------------|
| PROCEDURE STEP NO. (1) | FUNCTION TESTED (2) | NOMINAL (3) | MEASURED VALUES | | OUT OF TOL (6) | CALIBRATION TOLERANCES (7) |
| | | | FIRST RUN (4) | SECOND RUN (5) | | |
| 3.2 | Conn. dimen. | -- | ck () | | | See Appendix A |
| 3.3 | MODULATION meter | -- | ck () | | NA | Adjust for "0" ind. |
| 3.4 | FREQ ERROR meter | -- | ck () | | NA | Adjust for "0" ind. |
| 4.1 | Self Tests, Functional, and Power Supply Checks | | | | | |
| 4.1.1 | Self Test and Functional Checks | | | | | |
| 4.1.1.2 | keypad | -- | ck () | | NA | Tone for each key pressed |
| 4.1.1.4 | TRACK CRT display | -- | ck () | | NA | Noise pattern present |
| 4.1.1.5 | SWEEP CRT display | -- | ck () | | NA | Horizontal trace present |
| 4.1.1.6 | FREQS CRT display | -- | ck () | | NA | Menus present |
| 4.1.1.7 | TONES CRT display | -- | ck () | | NA | Menus present |
| 4.1.1.8 | HELP CRT display | -- | ck () | | NA | Menus present |
| 4.1.1.10 | Memory self-test | -- | ck () | | NA | No failures indicated |
| 4.1.1.11 | Character set self-test | -- | ck () | | NA | Full character set present |
| 4.1.1.12 | LCD self-test | -- | ck () | | NA | Scrolls right to left |
| 4.1.1.13 | LED/internal bus self-test | -- | ck () | | NA | No failures indicated |
| 4.1.1.14 | Menu self-test | -- | ck () | | NA | No failures indicated |
| 4.1.2 | Power Supply Checks | | | | | |
| 4.1.2.3 | +12 V dc check | +12.0 V dc | | | | +11.5 to +12.5 V dc |
| 4.1.2.4 | +5 V dc check | +5.0 " | | | | 4.85 to +5.30 " |
| 4.1.2.5 | -12 V dc check | -12.0 " | | | | -11.5 to 12.5 " |
| 4.2 | RF Signal Generator Tests | | | | | |
| 4.2.1 | RF Frequency Accuracy Tests | | | | | |
| | | (MHz) | | | | (MHz) |
| 4.2.1.3 | 10 MHz reference | 10.000000 | | | | 9.999995 to 10.000005 |
| " | " " " (Opt 02) | " | | | | 9.999995 to 10.000005 |
| | | (kHz) | | | | (kHz) |
| 4.2.1.6 | 500 kHz | 500 | | | | 499.99975 to 500.00025 |
| " | " " (Opt 02) | " | | | | 499.999975 to 500.000025 |

CALIBRATION CHECKLIST

TEST INST (S) IFR Inc. FM/AM-1500, FM/AM-1500OPT01,02, or FM/AM-1500OPT02
Communications Service Monitor

| PROC. NO. | NA 17-20AQ-289 | MFG. | MODEL | | SER. NO. | |
|---------------------------------|-----------------------------|--------------------|----------------------|-----------------------|-------------------------|-----------------------------------|
| PROCEDURE STEP NO. (1) | FUNCTION TESTED (2) | NOMINAL (3) | MEASURED VALUES | | OUT OF TOL (6) | CALIBRATION TOLERANCES (7) |
| | | | FIRST RUN (4) | SECOND RUN (5) | | |
| | | (MHz) | | | | (MHz) |
| 4.2.1.7 | 111.1111 MHz | 111.1111 | | | | 111.111044 to 111.111156 |
| " | " " (Opt 02) | " | | | | 111.111094 to 111.111106 |
| " | 222.2222 MHz | 222.2222 | | | | 222.222089 to 222.222311 |
| " | " " (Opt 02) | " | | | | 222.222189 to 222.222211 |
| " | 333.3333 MHz | 333.3333 | | | | 333.333133 to 333.333467 |
| " | " " (Opt 02) | " | | | | 333.333283 to 333.333317 |
| " | 444.4444 MHz | 444.4444 | | | | 444.444178 to 444.444622 |
| " | " " (Opt 02) | " | | | | 444.444378 to 444.444422 |
| " | 555.5555 MHz | 555.5555 | | | | 555.555222 to 555.555778 |
| " | " " (Opt 02) | " | | | | 555.555472 to 555.555528 |
| " | 666.6666 MHz | 666.6666 | | | | 666.666267 to 666.666933 |
| " | " " (Opt 02) | " | | | | 666.666567 to 666.666633 |
| " | 777.7777 MHz | 777.7777 | | | | 777.777311 to 777.778089 |
| " | " " (Opt 02) | " | | | | 777.777661 to 777.777739 |
| " | 888.8888 MHz | 888.8888 | | | | 888.888356 to 888.889244 |
| " | " " (Opt 02) | " | | | | 888.888756 to 888.888844 |
| " | 999.9999 MHz | 999.9999 | | | | 999.999400 to 1000.000400 |
| " | " " (Opt 02) | " | | | | 999.999850 to 999.999950 |
| 4.2.2 | Output Level Accuracy Tests | | | | | |
| | (10 MHz) | (dBm) | | | | (dBm) |
| 4.2.2.4 | 0 dBm output | 0.0 | | | | -2.0 to +2.0 |
| 4.2.2.7 | -10 " " | -10.0 | | | | -8.0 to -12.0 |
| " | -20 " " | -20.0 | | | | -18.0 to -22.0 |
| " | -30 " " | -30.0 | | | | -28.0 to -32.0 |
| " | -40 " " | -40.0 | | | | -38.0 to -42.0 |
| " | -50 " " | -50.0 | | | | -48.0 to -52.0 |
| " | -60 " " | -60.0 | | | | -58.0 to -62.0 |
| " | -70 " " | -70.0 | | | | -68.0 to -72.0 |
| " | -80 " " | -80.0 | | | | -78.0 to -82.0 |
| " | -90 " " | -90.0 | | | | -87.5 to -92.5 |
| " | -100 " " | -100.0 | | | | -97.5 to -102.5 |

CALIBRATION CHECKLIST

TEST INST (S) IFR Inc. FM/AM-1500, FM/AM-1500OPT01,02, or FM/AM-1500OPT02
 Communications Service Monitor

| PROC. NO. | NA 17-20AQ-289 | | MFG. | MODEL | | SER. NO. | |
|---------------------------------|----------------------------|--------------------|----------------------|-----------------------|-------------------------|-----------------------------------|-----------|
| PROCEDURE STEP NO. (1) | FUNCTION TESTED (2) | NOMINAL (3) | MEASURED VALUES | | OUT OF TOL (6) | CALIBRATION TOLERANCES (7) | |
| | | | FIRST RUN (4) | SECOND RUN (5) | | | |
| | (500 MHz) | (dBm) | | | | (dBm) | |
| 4.2.2.8 | 0 dBm output | 0.0 | | | | -2.0 | to +2.0 |
| " | -10 " " | -10.0 | | | | -8.0 | to -12.0 |
| " | -20 " " | -20.0 | | | | -18.0 | to -22.0 |
| " | -30 " " | -30.0 | | | | -28.0 | to -32.0 |
| " | -40 " " | -40.0 | | | | -38.0 | to -42.0 |
| " | -50 " " | -50.0 | | | | -48.0 | to -52.0 |
| " | -60 " " | -60.0 | | | | -58.0 | to -62.0 |
| " | -70 " " | -70.0 | | | | -68.0 | to -72.0 |
| " | -80 " " | -80.0 | | | | -78.0 | to -82.0 |
| " | -90 " " | -90.0 | | | | -87.5 | to -92.5 |
| " | -100 " " | -100.0 | | | | -97.5 | to -102.5 |
| | (999 MHz) | (dBm) | | | | (dBm) | |
| 4.2.2.8 | 0 dBm output | 0.0 | | | | -2.0 | to +2.0 |
| " | -10 " " | -10.0 | | | | -8.0 | to -12.0 |
| " | -20 " " | -20.0 | | | | -18.0 | to -22.0 |
| " | -30 " " | -30.0 | | | | -28.0 | to -32.0 |
| " | -40 " " | -40.0 | | | | -38.0 | to -42.0 |
| " | -50 " " | -50.0 | | | | -48.0 | to -52.0 |
| " | -60 " " | -60.0 | | | | -58.0 | to -62.0 |
| " | -70 " " | -70.0 | | | | -68.0 | to -72.0 |
| " | -80 " " | -80.0 | | | | -78.0 | to -82.0 |
| " | -90 " " | -90.0 | | | | -87.5 | to -92.5 |
| " | -100 " " | -100.0 | | | | -97.5 | to -102.5 |
| 4.2.3 | Residual FM Tests | | | | | | |
| 4.2.3.4 | 50 MHz - FM 4 | -- | ck () | | | <200 Hz FM | |
| 4.2.3.5 | " - FM 3 | -- | ck () | | | <50 Hz FM | |
| " | " - FM 2 | -- | ck () | | | " | |
| " | " - FM 1 | -- | ck () | | | " | |
| | | | | | | | |
| | | | | | | | |
| | | | | | | | |

CALIBRATION CHECKLIST

TEST INST (S) IFR Inc. FM/AM-1500, FM/AM-1500OPT01,02, or FM/AM-1500OPT02
 Communications Service Monitor

| PROC. NO. | NA 17-20AQ-289 | MFG. | MODEL | | SER. NO. | |
|------------------------|---------------------------------|-------------|-----------------|----------------|----------------|----------------------------|
| PROCEDURE STEP NO. (1) | FUNCTION TESTED (2) | NOMINAL (3) | MEASURED VALUES | | OUT OF TOL (6) | CALIBRATION TOLERANCES (7) |
| | | | FIRST RUN (4) | SECOND RUN (5) | | |
| 4.2.3.6 | 850 MHz - FM 4 | -- | ck () | | | <250 Hz FM |
| " | " - FM 3 | -- | ck () | | | <200 Hz FM |
| " | " - FM 2 | -- | ck () | | | " |
| " | " - FM 1 | -- | ck () | | | " |
| 4.2.4 | Spurious Signals Tests | | | | | |
| 4.2.4.4 | 100 kHz - harmonics | -- | ck () | | | >25 dBc |
| " | 100 kHz - non-harm. | -- | ck () | | | >40 dBc |
| 4.2.4.5 | 10 MHz - harmonics | -- | ck () | | | >25 dBc |
| " | 10 MHz - non-harm. | -- | ck () | | | >40 dBc |
| " | 500 MHz - harmonics | -- | ck () | | | >25 dBc |
| " | 500 MHz - non-harm. | -- | ck () | | | >40 dBc |
| " | 999 MHz - harmonics | -- | ck () | | | >25 dBc |
| " | 999 MHz - non-harm. | -- | ck () | | | >40 dBc |
| 4.3 | Duplex Generator Tests | | | | | |
| 4.3.1 | Duplex Frequency Accuracy Tests | | | | | |
| | | (MHz) | | | | (MHz) |
| 4.3.1.5 | OFFSET: 1.00 MHz | 801.00 | | | | 800.99960 to 801.00040 |
| " | " " " (Opt 02) | " | | | | 800.99996 to 801.00004 |
| 4.3.1.6 | " 11.11 " | 811.11 | | | | 811.10959 to 811.11041 |
| " | " " " (Opt 02) | " | | | | 811.10996 to 811.11004 |
| " | " 33.33 " | 833.33 | | | | 833.32958 to 833.33042 |
| " | " " " (Opt 02) | " | | | | 833.32996 to 833.33004 |
| " | " 49.99 " | 849.99 | | | | 849.98957 to 849.99043 |
| " | " " " (Opt 02) | " | | | | 849.98996 to 849.99004 |
| " | " -1.00 " | 799.00 | | | | 798.99960 to 798.00040 |
| " | " " " (Opt 02) | " | | | | 798.99996 to 799.00004 |
| | | | | | | |
| | | | | | | |
| | | | | | | |
| | | | | | | |
| | | | | | | |
| | | | | | | |
| | | | | | | |

CALIBRATION CHECKLIST

TEST INST (S) IFR Inc. FM/AM-1500, FM/AM-1500OPT01,02, or FM/AM-1500OPT02
 Communications Service Monitor

| PROC. NO. | NA 17-20AQ-289 | | MFG. | MODEL | | SER. NO. | |
|---------------------------------|------------------------------------|--------------------|------------------|-------------------|-------------------------|------------------------|--|
| PROCEDURE STEP NO. (1) | FUNCTION TESTED (2) | NOMINAL (3) | MEASURED VALUES | | OUT OF TOL (6) | CALIBRATION TOLERANCES | |
| | | | FIRST RUN (4) | SECOND RUN (5) | | (7) | |
| | | (MHz) | | | | (MHz) | |
| 4.3.1.6 | OFFSET: -11.11 MHz | 788.89 | | | | 788.88961 to 788.89039 | |
| " | " " " (Opt 02) | " | | | | 788.88996 to 788.89004 | |
| " | " -33.33 " | 766.67 | | | | 766.66962 to 766.67038 | |
| " | " " " (Opt 02) | " | | | | 766.66996 to 766.67004 | |
| " | " -49.99 " | 750.01 | | | | 750.00963 to 750.01038 | |
| " | " " " (Opt 02) | " | | | | 750.00996 to 750.01004 | |
| 4.3.2 | Duplex Output Level Accuracy Tests | | | | | | |
| | (810 MHz - Duplex Output) | (dBm) | | | | (dBm) | |
| 4.3.2.5 | 0 dBm output | 0.0 | | | | -2.0 to +2.0 | |
| 4.3.2.8 | -10 " " | -10.0 | | | | -8.0 to -12.0 | |
| " | -20 " " | -20.0 | | | | -18.0 to -22.0 | |
| " | -30 " " | -30.0 | | | | -28.0 to -32.0 | |
| " | -40 " " | -40.0 | | | | -38.0 to -42.0 | |
| " | -50 " " | -50.0 | | | | -48.0 to -52.0 | |
| " | -60 " " | -60.0 | | | | -58.0 to -62.0 | |
| " | -70 " " | -70.0 | | | | -68.0 to -72.0 | |
| " | -80 " " | -80.0 | | | | -78.0 to -82.0 | |
| " | -90 " " | -90.0 | | | | -87.5 to -92.5 | |
| " | -100 " " | -100.0 | | | | -97.5 to -102.5 | |
| | (810 MHz - Trans/-40 dB Output) | | | | | | |
| | | (dBm) | | | | (dBm) | |
| 4.3.2.12 | -50 dBm output | -50.0 | | | | -47.0 to -53.0 | |
| " | -60 " " | -60.0 | | | | -57.0 to -63.0 | |
| " | -70 " " | -70.0 | | | | -67.0 to -73.0 | |
| " | -80 " " | -80.0 | | | | -77.0 to -83.0 | |
| " | -90 " " | -90.0 | | | | -87.0 to -93.0 | |
| " | -100 " " | -100.0 | | | | -97.0 to 103.0 | |
| | | | | | | | |
| | | | | | | | |
| | | | | | | | |
| | | | | | | | |

CALIBRATION CHECKLIST

TEST INST (S) IFR Inc. FM/AM-1500, FM/AM-1500OPT01,02, or FM/AM-1500OPT02
 Communications Service Monitor

| PROC. NO. | NA 17-20AQ-289 | MFG. | MODEL | | SER. NO. | |
|---------------------------------|---------------------------------|--------------------|----------------------|-----------------------|-------------------------|-----------------------------------|
| PROCEDURE STEP NO. (1) | FUNCTION TESTED (2) | NOMINAL (3) | MEASURED VALUES | | OUT OF TOL (6) | CALIBRATION TOLERANCES (7) |
| | | | FIRST RUN (4) | SECOND RUN (5) | | |
| | (20 MHz - Duplex Output) | (dBm) | | | | (dBm) |
| 4.3.2.14 | 0 dBm output | 0.0 | | | | -2.0 to +2.0 |
| " | -10 " " | -10.0 | | | | -8.0 to -12.0 |
| " | -20 " " | -20.0 | | | | -18.0 to -22.0 |
| " | -30 " " | -30.0 | | | | -28.0 to -32.0 |
| " | -40 " " | -40.0 | | | | -38.0 to -42.0 |
| " | -50 " " | -50.0 | | | | -48.0 to -52.0 |
| " | -60 " " | -60.0 | | | | -58.0 to -62.0 |
| " | -70 " " | -70.0 | | | | -68.0 to -72.0 |
| " | -80 " " | -80.0 | | | | -78.0 to -82.0 |
| " | -90 " " | -90.0 | | | | -87.5 to -92.5 |
| " | -100 " " | -100.0 | | | | -97.5 to -102.5 |
| | (20 MHz - Trans/-40 dB Output) | | | | | |
| | | (dBm) | | | | (dBm) |
| " | -50 dBm output | -50.0 | | | | -47.0 to -53.0 |
| " | -60 " " | -60.0 | | | | -57.0 to -63.0 |
| " | -70 " " | -70.0 | | | | -67.0 to -73.0 |
| " | -80 " " | -80.0 | | | | -77.0 to -83.0 |
| " | -90 " " | -90.0 | | | | -87.0 to -93.0 |
| " | -100 " " | -100.0 | | | | -97.0 to -103.0 |
| 4.4 | Receiver/Monitor Tests | | | | | |
| 4.4.1 | Receiver Sensitivity Tests | | | | | |
| 4.4.1.5 | 120.5 MHz - FM 1 | -- | ck () | | | sig. gen. lev. ≤ -99 dBm |
| 4.4.1.7 | 120.5 MHz - FM 2 | -- | ck () | | | sig. gen. lev. ≤ -90 dBm |
| 4.4.2 | Adjacent Channel Rejection Test | | | | | |
| 4.4.2.4 | Main chan. 125.5 MHz | -- | ck () | | | NARecord sig. gen. level |
| 4.4.2.6 | Adj. chan. 125.525 MHz | -- | ck () | | | Sig. gen. lev. 25 dB |
| | | | | | | greater than 4.4.2.5 |
| 4.4.2.8 | Adj. chan. 125.55 MHz | -- | ck () | | | Sig. gen. lev. 40 dB |
| | | | | | | greater than 4.4.2.5 |

CALIBRATION CHECKLIST

TEST INST (S) IFR Inc. FM/AM-1500, FM/AM-1500OPT01,02, or FM/AM-1500OPT02
 Communications Service Monitor

| PROC. NO. | NA 17-20AQ-289 | MFG. | MODEL | | SER. NO. | |
|------------------------|--|-------------|-----------------|----------------|----------------|----------------------------|
| PROCEDURE STEP NO. (1) | FUNCTION TESTED (2) | NOMINAL (3) | MEASURED VALUES | | OUT OF TOL (6) | CALIBRATION TOLERANCES (7) |
| | | | FIRST RUN (4) | SECOND RUN (5) | | |
| 4.4.3 | FM Demodulation Noise + Distortion Test | | | | | |
| 4.4.3.11 | DEMOD OUTPUT | -- | ck () | | | Distortion less than 2% |
| 4.4.4 | Deviation Analog Meter and Digital Deviation Display (CRT) Tests | | | | | |
| 4.4.4.5 | 1 kHz FM - Analog | 1.0 kHz | | | | 0.9 to 1.1 kHz |
| 4.4.4.7 | 1 " " - SCOPE CRT | 4.0 div | | | | 3.6 to 4.4 div |
| 4.4.4.10 | 2 " " - CRT | 2.0 kHz | | | | 1.940 to 2.060 kHz |
| " | 2 " " - Analog | 2.0 kHz | | | | 1.7 to 2.3 kHz |
| 4.4.4.12 | 5 " " - Analog | 5.0 kHz | | | | 4.7 to 5.3 kHz |
| 4.4.4.14 | 1 " " - SCOPE CRT | 5.0 div | | | | 4.5 to 5.5 div |
| 4.4.4.17 | 8 " " - CRT | 8.0 kHz | | | | 7.760 to 8.240 kHz |
| " | 8 " " - Analog | 8.0 kHz | | | | 7.0 to 9.0 kHz |
| 4.4.4.19 | 15 " " - Analog | 15.0 kHz | | | | 14.0 to 16.0 kHz |
| 4.4.4.21 | 15 " " - SCOPE CRT | 6.0 div | | | | 5.4 to 6.6 div |
| 4.4.4.24 | 20 " " - SCOPE CRT | 20.0 kHz | | | | 17.0 to 23.0 kHz |
| 4.4.4.26 | 50 " " - SCOPE CRT | 50.0 kHz | | | | 47.0 to 53.0 kHz |
| 4.4.4.28 | 50 " " - SCOPE CRT | 5.0 div | | | | 4.5 to 5.5 div |
| 4.4.5.5 | AM Modulation Analog Meter and Digital AM Modulation Display (CRT) Tests | | | | | |
| 4.4.5.5 | 15% AM - CRT | 15% AM | | | | 12.2% to 17.8% AM |
| " | 15% " - Analog | 15% " | | | | 13.0% to 17.0% " |
| 4.4.5.8 | 30% " - CRT | 30% " | | | | 26.5% to 33.5% " |
| " | 30% " - Analog | 30% " | | | | 25% to 35% " |
| 4.4.5.10 | 50% " - CRT | 50% " | | | | 45.5% to 54.5% " |
| " | 50% " - Analog | 50% " | | | | 43% to 57% " |
| 4.4.5.13 | 80% " - CRT | 80% " | | | | 56% to 104% " |
| " | 80% " - Analog | 80% " | | | | 64% to 96% " |
| 4.4.5.14 | Speaker | -- | ck () | | NA | Audible tone |
| | | | | | | |
| | | | | | | |
| | | | | | | |
| | | | | | | |
| | | | | | | |

CALIBRATION CHECKLIST

TEST INST (S) IFR Inc. FM/AM-1500, FM/AM-1500OPT01,02, or FM/AM-1500OPT02
 Communications Service Monitor

| PROC. NO. | NA 17-20AQ-289 | MFG. | MODEL | SER. NO. | | |
|---------------------------------|--|----------------|------------------|-------------------|-------------------------|-------------------------------|
| PROCEDURE STEP NO. (1) | FUNCTION TESTED (2) | NOMINAL (3) | MEASURED VALUES | | OUT OF TOL (6) | CALIBRATION TOLERANCES (7) |
| | | | FIRST RUN (4) | SECOND RUN (5) | | |
| 4.5 | Spectrum Analyzer Tests | | | | | |
| 4.5.1 | Spectrum Analyzer Linearity Tests (dB) | | | | | (dB) |
| 4.5.1.7 | -30 dB graticule | +10.0 | | | | +8.0 to +12.0 |
| " | -50 dB " | -10.0 | | | | -8.0 to -12.0 |
| " | -60 dB " | -20.0 | | | | -18.0 to -22.0 |
| " | -70 dB " | -30.0 | | | | -28.0 to -32.0 |
| " | -80 dB " | -40.0 | | | | -38.0 to -42.0 |
| " | -90 dB " | -50.0 | | | | -48.0 to -52.0 |
| 4.5.2 | Antenna Attenuator Tests | (dB) | | | | (dB) |
| 4.5.2.5 | 20 dB attenuator | +20.0 | | | | +18.0 to +22.0 |
| 4.5.2.8 | 40 dB " | +40.0 | | | | +38.0 to +42.0 |
| 4.5.3 | Spectrum Analyzer Dispersion Tests | | | | | |
| 4.5.3.5 | 1 kHz/DIV +4 kHz | 4.0 div | | | | 3.7 to 4.3 div to right |
| 4.5.3.6 | " -4 " | " | | | | " " left |
| 4.5.3.7 | 2 kHz/DIV +8 " | " | | | | " " right |
| " | " 8 " | " | | | | " " left |
| " | 10 kHz/DIV +40 " | " | | | | " " right |
| " | " -40 " | " | | | | " " left |
| " | 20 kHz/DIV +80 " | " | | | | " " right |
| " | " -80 " | " | | | | " " left |
| " | .1 MHz/DIV +400 " | " | | | | " " right |
| " | " -400 " | " | | | | " " left |
| " | .2 MHz/DIV +800 " | " | | | | " " right |
| " | " -800 " | " | | | | " " left |
| " | .5 MHz/DIV +2 MHz | " | | | | " " right |
| " | " -2 " | " | | | | " " left |
| " | 1 MHz/DIV +4 " | " | | | | " " right |
| " | " -4 " | " | | | | " " left |
| " | 2 MHz/DIV +8 " | " | | | | " " right |
| " | " -8 " | " | | | | " " left |
| " | 5 MHz/DIV +20 " | " | | | | " " right |
| " | " 20 " | " | | | | " " left |

CALIBRATION CHECKLIST

TEST INST (S) IFR Inc. FM/AM-1500, FM/AM-1500OPT01,02, or FM/AM-1500OPT02
 Communications Service Monitor

| PROC. NO. | NA 17-20AQ-289 | MFG. | MODEL | | SER. NO. | |
|---------------------------------|---|----------------|------------------|-------------------|-------------------------|-------------------------------|
| PROCEDURE STEP NO. (1) | FUNCTION TESTED (2) | NOMINAL (3) | MEASURED VALUES | | OUT OF TOL (6) | CALIBRATION TOLERANCES (7) |
| | | | FIRST RUN (4) | SECOND RUN (5) | | |
| 4.5.3.7 | 10 kHz/DIV +40 MHz | 4.0 div | | | | 3.7 to 4.3 div to right |
| " | " -40 " | " | | | | " " left |
| 4.6 | Oscilloscope Tests | | | | | |
| 4.6.5 | .01 V/DIV 50 mV p-p | 5.0 div | | | | 4.5 to 5.5 divisions |
| " | .1 " 500 " | " | | | | " |
| " | 1 " 5 V p-p | " | | | | " |
| " | 10 " 50 " | " | | | | " |
| 4.6.6 | VERT VERNIER fully ccw | -- | ck () | | | CRT display <2.5 div p-p |
| 4.6.11 | .01 mS/DIV 100 kHz | 10 cycles | | | | 8 to 12 full cycles on CRT |
| 4.6.13 | .1 " 10 " | " | | | | " |
| 4.6.15 | 1 " 1 " | " | | | | " |
| 4.6.17 | 10 " 100 Hz | " | | | | " |
| 4.7 | Dual Tone Generator Tests | | | | | |
| 4.7.1 | Dual Tone Generator Frequency Accuracy and Output Level Tests (TONE 1 Generator) | | | | | |
| 4.7.1.5 | 20 Hz - output | -- | ck () | | | Output level ≥2.5 V rms |
| 4.7.1.6 | " " - freq acc | 20 Hz | | | | 19.998 to 10.002 Hz |
| " | " " - Demod Count | " | | | | 18 to 22 " |
| 4.7.1.7 | 100 " - output | -- | ck () | | | Output level ≥2.5 V rms |
| " | " " - freq acc | 100 Hz | | | | 99.99 to 100.01 Hz |
| " | " " - Demod Count | " | | | | 98 to 102 " |
| " | 1 kHz - output | -- | ck () | | | Output level ≥2.5 V rms |
| " | " " - freq acc | 1000 Hz | | | | 999.9 to 1000.1 Hz |
| " | " " - Demod Count | " | | | | 998 to 1002 " |
| " | 5 " - output | -- | ck () | | | Output level ≥2.5 V rms |
| " | " " - freq acc | 5000 Hz | | | | 4999.5 to 5000.5 Hz |
| " | " " - Demod Count | " | | | | 4998 to 5002 " |
| " | 10 " - output | -- | ck () | | | Output level ≥2.5 V rms |
| " | " " - freq acc | 10000 Hz | | | | 9999 to 10001 Hz |
| " | " " - Demod Count | " | | | | 9998 to 10002 " |

CALIBRATION CHECKLIST

TEST INST (S) IFR Inc. FM/AM-1500, FM/AM-1500OPT01,02, or FM/AM-1500OPT02
 Communications Service Monitor

| PROC. NO. | NA 17-20AQ-289 | MFG. | MODEL | | SER. NO. | |
|---------------------------------|--------------------------------------|--------------------|----------------------|-----------------------|-------------------------|-----------------------------------|
| PROCEDURE STEP NO. (1) | FUNCTION TESTED (2) | NOMINAL (3) | MEASURED VALUES | | OUT OF TOL (6) | CALIBRATION TOLERANCES (7) |
| | | | FIRST RUN (4) | SECOND RUN (5) | | |
| 4.7.1.7 | 20 kHz - output | -- | ck () | | | Output level ≥ 2.5 V rms |
| " | " - freq acc | 20000 Hz | | | | 19998 to 20002 Hz |
| " | " - Demod Count | " | | | | 19998 to 20002 " |
| | (TONE 2 Generator) | | | | | |
| 4.7.1.9 | 20 Hz- output | -- | ck () | | | Output level ≥ 2.5 V rms |
| " | " - freq acc | 20 Hz | | | | 19.998 to 20.002 Hz |
| " | " - Demod Count | " | | | | 18 to 22 " |
| " | 100 " - output | -- | ck () | | | Output level ≥ 2.5 V rms |
| " | " - freq acc | 100 Hz | | | | 99.99 to 100.01 Hz |
| " | " - Demod Count | " | | | | 98 to 102 " |
| " | 1 kHz - output | -- | ck () | | | Output level ≥ 2.5 V rms |
| " | " - freq acc | 1000 Hz | | | | 999.9 to 1000.1 Hz |
| " | " - Demod Count | " | | | | 998 to 1002 " |
| " | 5 " - output | -- | ck () | | | Output level ≥ 2.5 V rms |
| " | " - freq acc | 5000 Hz | | | | 4999.5 to 5000.5 Hz |
| " | " - Demod Count | " | | | | 4998 to 5002 " |
| " | 10 " - output | -- | ck () | | | Output level ≥ 2.5 V rms |
| " | " - freq acc | 10000 Hz | | | | 9999 to 10001 Hz |
| " | " - Demod Count | " | | | | 9998 to 10002 " |
| " | 20 kHz - output | -- | ck () | | | Output level ≥ 2.5 V rms |
| " | " - freq acc | 20000 Hz | | | | 19998 to 20002 Hz |
| " | " - Demod Count | " | | | | 19998 to 20002 " |
| 4.7.2 | Dual Tone Generator Distortion Tests | | | | | |
| 4.7.2.3 | Tone 1 - 1 kHz | -- | ck () | | | Distortion <0.7% |
| 4.7.2.5 | " - 10 kHz | -- | ck () | | | " " |
| 4.7.2.7 | " - 20 kHz | -- | ck () | | | " " |
| 4.7.2.9 | " - 50 Hz | -- | ck () | | | " <2.0% |
| 4.7.2.11 | Tone 2 - 1 kHz | -- | ck () | | | Distortion <0.7% |
| " | " - 10 kHz | -- | ck () | | | " " |
| " | " - 2 kHz | -- | ck () | | | " " |
| " | " - 50 Hz | -- | ck () | | | " <2.0% |

CALIBRATION CHECKLIST

TEST INST (S) IFR Inc. FM/AM-1500, FM/AM-1500OPT01,02, or FM/AM-1500OPT02
 Communications Service Monitor

| PROC. NO. | NA 17-20AQ-289 | MFG. | MODEL | | SER. NO. | |
|-----------|-----------------------------|----------------|------------------|-------------------|-------------------|-------------------------------|
| | FUNCTION TESTED (2) | NOMINAL (3) | MEASURED VALUES | | OUT OF TOL (6) | CALIBRATION TOLERANCES (7) |
| | | | FIRST RUN (4) | SECOND RUN (5) | | |
| 4.8 | Frequency Error Meter Tests | | | | | |
| | FREQ ERROR Sig. Gen. | | | | | |
| | Meter Set. Freq. Diff. | | | | | |
| 4.8.5 | 10 kHz +5 kHz | +0.5 | | | | +0.4 to +0.6 |
| 4.8.7 | 10 " -5 " | -0.5 | | | | -0.4 to -0.6 |
| 4.8.8 | 1 kHz +500 Hz | +0.5 | | | | +0.4 to +0.6 |
| " | 1 " -500 " | -0.5 | | | | -0.4 to -0.6 |
| " | 100 Hz +50 Hz | +0.5 | | | | +0.4 to +0.6 |
| " | 100 " -50 " | -0.5 | | | | -0.4 to -0.6 |
| 4.8.11 | 3 kHz +2 kHz | +2.0 | | | | +1.9 to +2.1 |
| 4.8.13 | 3 " -2 " | -2.0 | | | | -1.9 to -2.1 |
| 4.8.14 | 300 Hz +200 Hz | +2.0 | | | | +1.9 to +2.1 |
| " | 300 " -200 " | -2.0 | | | | -1.9 to -2.1 |
| " | 30 Hz +20 Hz | +2.0 | | | | +1.9 to +2.1 |
| " | 30 " -20 " | -2.0 | | | | -1.9 to -2.1 |
| 4.9 | Internal SINAD Meter Test | | | | | |
| 4.9.4 | TONE 1 - max output | -- | ck () | | NA | Record DMM ind. |
| 4.9.9 | Analog SINAD meter | 12 dB | | | | 11 to 13 dB SINAD |
| " | CRT SINAD reading | " | | | | " |
| 4.10 | Power Monitor Tests | | | | | |
| | (30 MHz) | (W) | | | | (W) |
| 4.10.5 | 10 W - Analog meter | 10 | | | | 8.85 to 11.15 |
| 4.10.7 | " - CRT meter | " | | | | " |
| 4.10.10 | 80 W - Analog meter | 80 | | | | 69.9 to 90.1 |
| 4.10.12 | " - CRT meter | " | | | | " |
| | (400 MHz) | (W) | | | | (W) |
| 4.10.14 | 80 W - Analog meter | 80 | | | | 69.9 to 90.1 |
| " | " - CRT meter | " | | | | " |
| 4.10.16 | 10 W - Analog meter | 10 | | | | 8.85 to 11.15 |
| " | " - CRT meter | " | | | | " |

APPENDIX A

DIMENSIONAL TOLERANCES FOR CRITICAL PORTIONS OF MILITARY TYPE N CONNECTORS
USED IN PRECISION MEASUREMENT EQUIPMENT

Information for the drawings was derived from Military Specifications MIL-C-71B and MIL-C-39012/
() D. MIL-C-39012/() D supersedes MIL-C-71B as of 23 Nov. 1966.

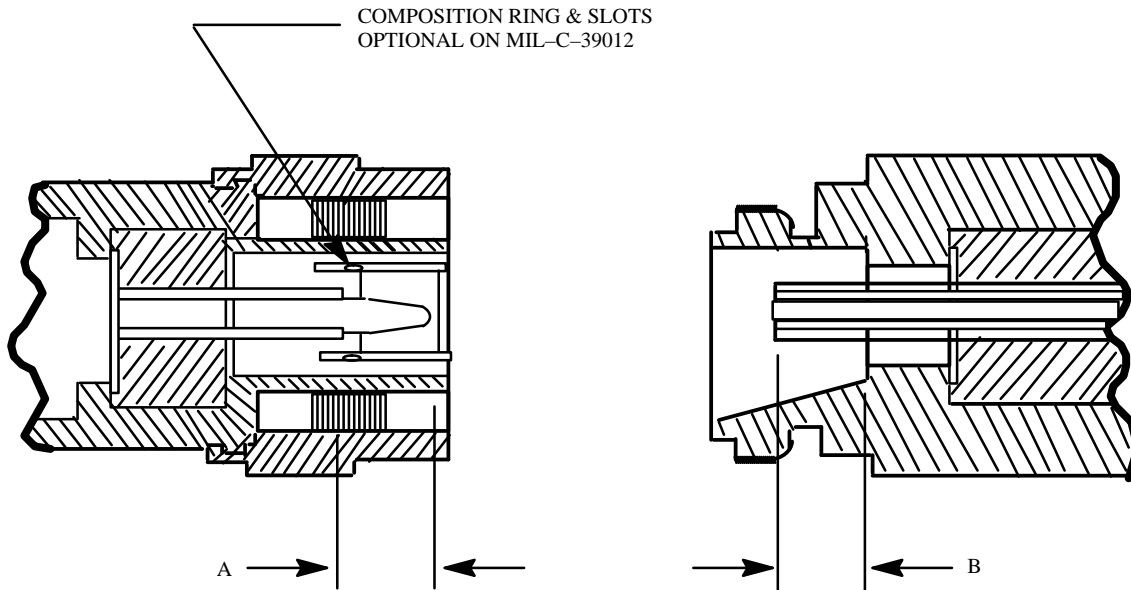

NOTE:
IF THE TI CANNOT BE IDENTIFIED
AS BEING BUILT TO MIL-C-71B,
MIL-C-39012/() D OR SPECIFIC
MANUFACTURER'S SPECIFICATIONS,
USE A TOLERANCE OF 0.208" TO 0.233"
FOR THE TYPE-N MALE AND 0.187"
TO 0.207" FOR THE TYPE-N FEMALE.

| SPECIFICATION | (MALE) A (INCHES) | (FEMALE) B (INCHES) |
|---------------------------------|-------------------------|---------------------------|
| MIL-C-39012/() D (CLASS II) | 0.210 MIN | 0.197 ±0.010 |
| MIL-C-71B | 0.223 ±0.010 | 0.197 ±0.010 |

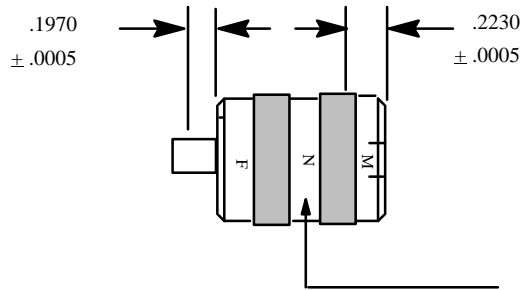

MIL-C-71B
MASTER GAGE

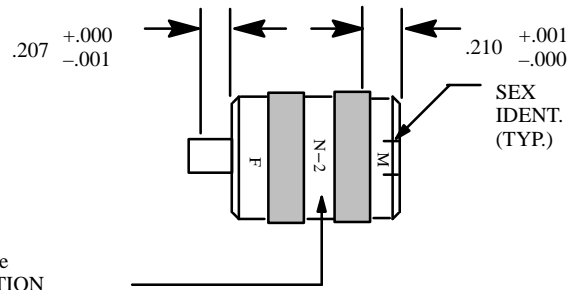

MIL-C-39012/() D
MASTER GAGE

MIL-C Type
IDENTIFICATION

NOTE:
THE MAURY A-007
KIT SPECIFIED IN
SECTION 2 CONTAINS
ONLY THE MIL-C-71B
GAGE.

NOTE:
THE MAURY A-007A
KIT SPECIFIED IN
SECTION 2 CONTAINS
THE MIL-C-71B AND
MIL-C-39012 GAGES.